

WARNING

- Operation of this UTV by children under the age of 16
Increase of the risk of severe injury or death.
- An adult supervision required always.
- Never permit children under age 16 to operate this UTV.
- Overloading can adversely affect vehicle handling.
- Operator use only, passengers prohibited.
- This vehicle is designed and manufactured for OFF-ROAD
use only.
- Driving on public streets, roads or highways is illegal.
- Always wear helmet and other protective equipment.
- Do not operate this vehicle after consuming Alcohol or Drugs.
- Gasoline is flammable, when refueling. Pis shut off engine to
avoid sparks and open flame.
- Read owner's manual carefully before riding. Keep owner's
manual with vehicle.

 WARNING
--

<p>Read, understand, and follow all of the instructions and safety precautions in this manual and on all product labels. Failure to follow the safety precautions could result in serious injury or death.</p>
--

 WARNING
--

<p>The engine exhaust from this product contains chemicals known to the State of California to cause cancer, birth defects or other reproductive harm.</p>
--

PAY ATTENTION TO YOUR SAFETY

This section presents some of the most important information and recommendations to help you ride your UTV safely. Please take a few moments to read these pages. This section also includes information about the location of safety labels on your UTV.

Important safety information

Your UTV can provide many years of service and pleasure—if you take responsibility for your own safety and understand the challenges you can meet while riding.

There is much that you can do to protect yourself when you ride. You'll find many helpful recommendations throughout this manual. The following are a few that we consider most important.

Follow the age recommendation

The minimum recommended age of this UTV model is 16. Children under age 16 should never operate this vehicle.

Always wear a helmet

It's a proven fact: helmets significantly reduce the number and severity of head injuries. So always wear an approved motorcycle helmet. We also recommend that you wear eye protection, sturdy boots, gloves, and other protective gear.

Ride off-road only

Your UTV is designed and manufactured for off-road use only. The tires are not made for pavement, and the UTV does not have turn signals and other features required for use on public roads. If you need to cross a paved or public road, get off and walk your UTV across.

Take time to learn & practice

Even if you have ridden other UTVs, take time to become familiar with your skills and get accustomed to the UTV's size and weight.

Because many accidents involve inexperienced or untrained riders, we urge all riders to take

a training course approved by the UTV safety institute.

Contact an authorized UTV dealer to find out about the training courses nearest you.

Be alert for off-road hazards

The terrain can present a variety of challenges when you ride off-road. Continually “read” the terrain for unexpected turns, drop-offs, rocks, ruts, and other hazards. Always keep your speed low enough to allow time to see and react to hazards.

Ride within your limits

Pushing limits is another major cause of UTV accidents. Never ride beyond your personal abilities or faster than conditions warrant.

Remember that alcohol, drugs, fatigue, and inattention can significantly reduce your ability to make good judgments and ride safely.

Don’ t drink and ride

Alcohol and riding don’ t mix. Even one drink can reduce your ability to respond to changing conditions, and your reaction time gets worse with every additional drink. So don’ t drink and ride, and don’ t let your friends drink and ride either.

Keep your UTV in safe condition

It’ s important to keep your UTV properly maintained and in safe riding condition. Having a breakdown can be difficult, especially if you are stranded off-road far from your base. To help avoid problems, inspect your UTV before every ride and perform all recommended maintenance.

Your UTV comes with a hangtag and several labels containing important safety information. Anyone who rides the vehicle should read and understand this information before riding.

The labels should be considered permanent parts of the vehicle. If a label comes off or becomes hard to read, contact your dealer for replacement

GUIDELINES ON SAFE DRIVING

1. When approaching corners or bends to reduce speed. Upon the completion of turn, may gradually increase the speed.
2. When crossing the vehicles parked in front of, to be very careful. Because the driver of the vehicle may be invisible to you and the door opened, the forward block in your way.
3. Brake Lining may Motorcycle rinsing wetting lose their role, so when cleaning End after walking ago, should check all brake system.

For training please call ASI at 1-800-431-0854

Instruments & Controls

This section shows the location of all indicators and controls you would normally use before or while riding your UTV.

This items listed on this page are described in this section. Instructions for other components are presented in other sections of this manual where they will be most useful.

WELCOME

Dear Parents:

We believe your children should have the opportunity to enjoy The Way Out, experience along with you. We encourage you to teach your children to ride safely, and to help ensure the future of recreational sports, please teach them to show respect for our environment and for the rights of others while operating the vehicle.

This vehicle is not a toy and can be hazardous to operate. We've provided

this owner's manual and an instructional video to help you and your children learn about the safe operation and care of your new Yours vehicle. Before your children drive or ride in the vehicle, please read and make sure they read this owner's manual. Watch the instructional video with them. Make sure all operators and passengers understand and follow all of the instructions and warnings contained in the owner's manual and video. Make sure they understand that the vehicle must be used under adult supervision at all times.

After reading the owner's manual and watching the video, help your child practice the New Operator Driving Procedures on pages 47–48.

Never allow a child age 16 and under to operate or ride as a passenger in this vehicle. Children differ in skills, physical abilities and judgement.

Please supervise the use of the vehicle at all times. Permit continued use only if you determine that your child has the ability and maturity to operate safely.

Make sure your child is not too tall to ride safely in this vehicle. See page 17.

The vehicle's speed control system allows adults to limit vehicle speed for new and inexperienced operators. Please see page 40 for more information.

The preventive maintenance program outlined in this manual is designed to ensure that all critical components on your child's vehicle

WELCOME

are thoroughly inspected at specific intervals. Always follow all of the instructions and recommendations in this manual to ensure the vehicle remains in safe operating condition at all times.

This Yours vehicle is not designed for adult use. Serious damage may occur if the maximum weight capacity is exceeded. Refer to vehicle labels and to the specifications section beginning on page 97 for the maximum weight capacity.

Dear Young Operators:

Before you ride your new Yours vehicle, there are some important things that you need to know. You must learn how to keep yourself and those around you safe while you're riding.

Your parents and Yours want you to be safe while you enjoy riding your new vehicle, and that's why it's very important that you read this owner's manual and watch the instructional video. Make sure you understand and follow all of the instructions and warnings in the owner's manual and video. Ask your parents to explain anything you don't understand.

Your safety and the safety of others is the most important thing to think about at all times. Pay attention when you see this symbol:

▲This is the safety alert symbol. When you see this symbol on your vehicle or in this manual it means PAY ATTENTION because you could die or be seriously injured if you don't follow the instructions.

After reading the owner's manual and watching the video, complete the New Operator Driving Procedures on pages 47–48. Show your parent that you understand how to drive safely.

Enjoy riding your new Yours vehicle!

TABLE OF CONTENTS

Introduction	9
Safety	12
Features and Controls	31
Operation	45
Emission Control Systems	61
Maintenance	62
Specifications	104
Troubleshooting	112
Maintenance Log	116
Index	118

INTRODUCTION

The following signal words and symbols appear throughout this manual and on your vehicle. Your safety is involved when these words and symbols are used. Become familiar with their meanings before reading the manual.



The safety alert symbol indicates a potential personal injury hazard.

WARNING

A **WARNING** indicates a hazardous situation which, if not avoided, may result death or serious injury.

CAUTION

A **CAUTION** indicates a hazardous situation which, if not avoided, may result in minor or moderate injury.

NOTICE

A **NOTICE** indicates a situation that may result in property damage.



The Prohibition Safety Sign indicates an action **NOT** to take in order to avoid a hazard.



The Mandatory Action Sign indicates an action that **NEEDS** to be taken to avoid a hazard.

INTRODUCTION

! WARNING

Failure to follow the warnings and safety precautions contained in this manual can result in severe injury or death. Your Yours vehicle is not a toy and can be hazardous to operate. This vehicle handles differently than cars, trucks or other off road vehicles. A collision or rollover can occur quickly, even during routine maneuvers like turning, or driving on hills or over obstacles, if you fail to take proper precautions.

- Read this owner's manual. Understand all safety warnings, precautions and operating procedures before driving the vehicle. Keep this manual with the vehicle.

- Never operate this vehicle without proper instruction. All operators and supervising adults must watch the instructional video that was provided with the vehicle.

Complete the New Operator Driving Procedures outlined on pages 47–48.

- Always follow the age guidelines for your vehicle. Operation is prohibited for anyone age 16 and under. Never operate with a passenger age 16 and under.

- Never allow a guest to operate this vehicle until the guest has watched the

instructional video and has completed the New Operator Driving Procedures on pages 47–48.

INTRODUCTION

Vehicle Identification Numbers

Record your vehicle's identification numbers and key number in the spaces

provided. Remove the spare key and store it in a safe place. An ignition key

can be duplicated only by ordering a Yours key blank and mating it with one

of your existing keys.

The ignition switch must be replaced if all keys are lost.



Vehicle Identification Number

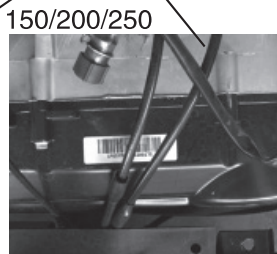
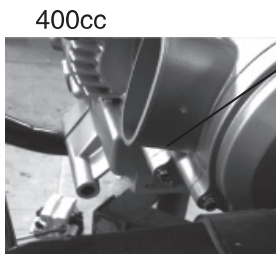

Engine Serial Number
(Under the back cover)

Vehicle Model Number: _____

Vehicle Identification Number: _____

Engine Serial Number: _____

SAFETY

Equipment Modifications

Your Yours vehicle is designed to provide safe operation when used as directed. Modifications to your vehicle may negatively impact vehicle stability. Failure of critical machine components may result from operation with any modifications, especially those that increase speed or power. This vehicle may become less stable at speeds higher than those for which it is designed. Loss of control may occur at higher speeds.

Do not install on a Yours vehicle any equipment that may increase the speed or power of the vehicle, or make any other modifications to the vehicle for these purposes. Any modifications to the original equipment of the vehicle create a substantial safety hazard and increase the risk of bodily injury.

The warranty on your Yours vehicle is terminated if any equipment has been added to the vehicle, or if any modifications have been made to the vehicle, that increase its speed or power.

The addition of certain accessories may change the handling characteristics of the vehicle. Use only Yours–approved accessories, and familiarize yourself with their function and effect on the vehicle.

SAFETY

Safe Riding Gear

Always wear appropriate clothing when riding a Yours vehicle. Wear protective clothing for comfort and to reduce the chance of injury.

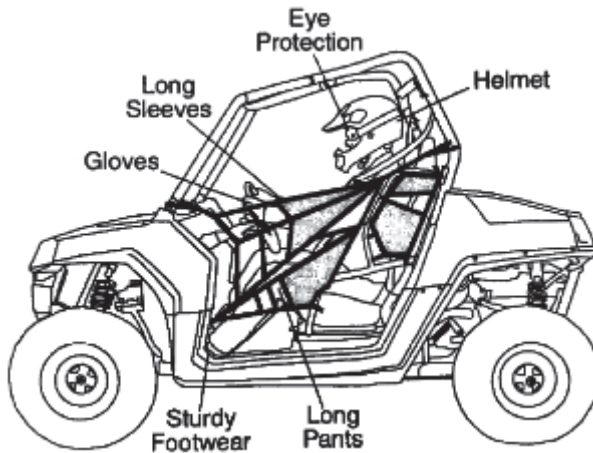

Helmet

Wearing a helmet can prevent a severe head injury. Whenever riding this Yours vehicle, always wear a helmet that meets or exceeds established safety standards.

Approved helmets in the USA and Canada bear a U.S. Department of Transportation(DOT) label.

Approved helmets in Europe, Asia and Oceania bear the ECE 22.05 label. The ECE mark consists of a circle surrounding the letter E, followed by the distinguishing number of the country which has granted approval. The approval number and serial number will also be displayed on the label.

SAFETY

Safe Riding Gear

Eye Protection

Do not depend on eyeglasses or sunglasses for eye protection. Whenever riding a Yours vehicle, always wear shatterproof goggles or use a shatterproof helmet face shield. Yours recommends wearing approved

Personal Protective Equipment (PPE) bearing markings such as VESC 8, V-8, Z87.1, or CE. Make sure protective eye wear is kept clean.

Gloves

Wear gloves for comfort and for protection from sun, cold weather and other elements.

Boots

Wear sturdy footwear. Do not ride a Yours vehicle with bare feet.

Clothing

Wear long sleeves and long pants to protect arms and legs.

Safety Warnings

! WARNING

Failure to operate this vehicle properly can result in a collision, loss of control, accident or overturn, which may result in serious injury or death. Be sure to read all of the following warnings about driving hazards and how to avoid them. These warnings are provided for your child's safety. Be sure to explain to your young driver that the hazards outlined in this section of the owner's manual **MUST** be avoided at all times. See the OPERATION section the owner's manual for proper operating procedures.

Operating Without Instruction

Operating this vehicle without proper instruction increases the risk of an accident. The operator and the supervising adult must understand how to operate the vehicle properly in different situations and on different types of terrain. Complete the New Operator Driving Procedures outlined on pages 51–52.

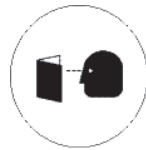

All operators must read and understand the owner's manual and all warning and instruction labels before operating the vehicle. Never allow a guest to operate this vehicle until the guest has read this manual and all product labels and has completed the New Operator Driving Procedures outlined on pages 51–52.

SAFETY

Age Restrictions

This vehicle is for recreational use by young operators under adult supervision ONLY. Operation is prohibited for anyone age 16 and under. Never operate with a passenger age 16 and under. Make sure any passenger is tall enough to comfortably and safely reach the hand holds and place both feet on the floor.



Age Restrictions

Some riders may be too tall to ride safely in this vehicle. Do not operate or ride in this vehicle if the clearance between the top of your helmet and the overhead cab frame is less than 2 inches (5 cm).

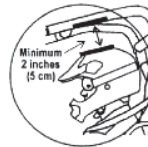

Safety Warnings

Failure to Inspect Before Operating
Failure to inspect and verify that the vehicle is in safe operating condition before operating increases the risk of an accident.

Always inspect the vehicle before each use to make sure it's in safe operating condition.

Always follow the inspection and maintenance procedures and schedules described in the owner's manual.



Accessories

Installing non-approved accessories may seriously affect vehicle handling and stability, which could result in loss of control or an accident. Never install accessories not approved by Yours for use on this vehicle.

Protective Apparel

Riding in this vehicle without wearing an approved helmet and protective eyewear increases the risk of serious injury in the event of an accident.

Operator and passenger must always wear an approved helmet that fits properly and eye protection (goggles or face shield).



SAFETY

Seat Belts

Riding in this vehicle without wearing the seat belt increases the risk of serious injury in the event of an accident or sudden stop. Riders must wear seat belts at all times. Seat belts reduce the severity of injury in the event of a sudden stop or accident. Always make sure the seat belts are secured for both the operator and passenger before riding.

Cab Nets/Side Guards

Riding in this vehicle without using the cab nets and side guards increases the risk of serious injury or death in the event of an accident or overturn. Always use the cab nets and side guards while riding in this vehicle.

Always keep hands and feet inside the vehicle at all times.

Safety Warnings

Using Alcohol or Drugs

Riding in this vehicle after consuming alcohol or drugs could adversely affect operator judgment, reaction time, balance and perception.

Never consume alcohol or drugs before or while operating or riding in this vehicle.



Carrying a Passenger

Never carry a passenger until you have operated this vehicle for at least four hours and have completed the New Operator Driving Procedures outlined on pages 51–52.

Carrying Multiple Passengers

Carrying more than one passenger in this vehicle can affect the operator's ability to steer and operate the controls, which increases the risk of loss of control and accident or overturn. Never carry more than one passenger in this vehicle.



Operating on Pavement

Operating this vehicle on paved surfaces (including sidewalks, paths, parking lots, and driveways) may seriously affect handling and control of the vehicle, and may cause the vehicle to go out of control. This vehicle's tires are designed for off-road use only, not for use on pavement.

Avoid operating the vehicle on pavement. If you must operate on a paved surface, travel slowly and do not make sudden turns or stops.

SAFETY

Operating on Public Roads

Operating this vehicle on public streets, roads or highways could result in a collision with another vehicle.

Never operate this vehicle on any public street, road or highway, including dirt and gravel roads.

In many areas it's unlawful to operate vehicles of this type on public streets, roads and highways.



Safety Warnings

Operating at Excessive Speeds

Operating this vehicle at excessive speeds increases the operator's risk of losing control. Always operate at a speed that's appropriate for the terrain, the visibility and operating conditions, your skills and your passenger's skills.



Turning Improperly

Turning improperly could cause loss of traction, loss of control, accident or overturn. Always follow proper procedures for turning as described in the owner's manual.

Never turn abruptly or at sharp angles. Never turn at high speeds. Practice turning at slow speeds before attempting to turn at faster speeds.

Physical Control of the Vehicle

Removing hands from the steering wheel or hand holds or removing feet from the floor while riding increases the risk of loss of control and accident or overturn.

The operator should always keep both hands on the steering wheel during operation. A passenger should always be seated in the passenger seat with both feet on the floor and with both hands securely grasping the hand holds.

Always keep hands and feet inside the vehicle at all times.

SAFETY

Jumps and Stunts

Exhibition driving increases the risk of an accident or overturn. DO NOT do power sides, "donuts", jumps or other driving stunts. Avoid exhibition driving.

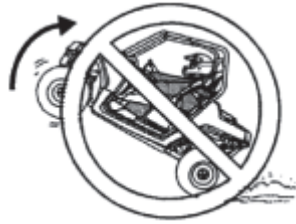

Safety Warnings

Driving Downhill Improperly

Driving down a hill improperly could cause loss of control or overturn. Always follow proper procedures for driving down a hill as described in the owner's manual.

- Always drive down a hill with the transmission in forward gear. Never drive down a hill with the transmission in neutral.
- Never operate the vehicle on hills steeper than 15 degrees.
- Always check the terrain carefully before driving down a hill.
- Never travel down a hill at high speed.
- Avoid traveling down a hill at an angle, which would cause the vehicle to lean sharply to one side. Travel straight downhill.

Improper Hill Climbing

Improper hill climbing could cause loss of control or overturn. Use extreme caution when operating on hills. Always follow proper procedures for hill climbing as described in the owner's manual. See page 51. Never operate the vehicle on hills steeper than 15 degrees.

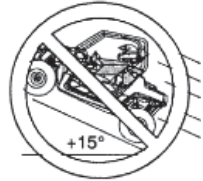

SAFETY

Safety Warnings

Stalling While Climbing a Hill

Stalling or rolling backwards while climbing a hill could cause an overturn. Maintain a steady speed when climbing a hill.

If you lose all foot/yard speed:

Apply the brakes gradually until the vehicle is fully stopped. Place the transmission in reverse and slowly allow the vehicle to roll straight downhill while applying light brake pressure to control speed.

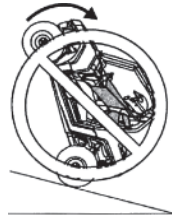

Crossing Hillside

Driving on a sidehill is not recommended.

Improper procedure could cause loss of control or overturn. Avoid crossing the side of any hill unless absolutely necessary.

If crossing a hillside is unavoidable, always follow procedures as Described in the owner's manual. See page 56.

Operating in Unfamiliar Terrain

Failure to use extra caution when operating on unfamiliar terrain could result in an accident or overturn.



Unfamiliar terrain may contain hidden rocks, bumps, or holes that could cause loss of control or overturn.

Travel slowly and use extra caution when operating on unfamiliar terrain. Always be alert to changing terrain conditions.

Safety Warnings

Operating on Sand or Slippery Terrain

Operating on sand or on excessively, rough, slippery or loose terrain could cause loss of traction, loss of control, accident or overturn.

Always use extra caution when operating on sand or on rough, slippery or loose terrain.

Do not operate on excessively rough, slippery or loose terrain.



Operating Improperly in Reverse

Improperly operating in reverse could result in a collision with an obstacle or person. Always follow proper operating procedures as outlined in this manual.

See page 59.

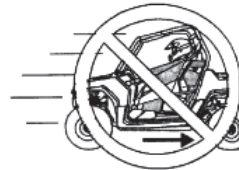

Before shifting into reverse gear, always check for obstacles or people behind the vehicle. When it's safe to proceed, back slowly.

Improper Tires and Maintenance

Installing non-approved tires may seriously affect vehicle handling and stability, which could result in loss of control or an accident.

Never install tires not approved by Yours for use on this vehicle.

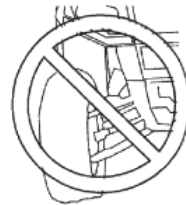

Operating this vehicle with improper or uneven tire pressure could cause loss of control, accident or overturn. Always maintain proper tire pressure as described in the owner's manual and on safety labels.

SAFETY

Safety Warning

Operating Over Obstacles

Improperly operating over obstacles could cause loss of control or overturn.

Before operating in a new area, check for obstacles. Never attempt to operate

over large obstacles such as rocks or fallen trees. Always follow the proper procedures outlined in this manual when operating over obstacles.



Skidding or Sliding

Skidding or sliding can cause loss of control or overturn (if tires regain traction unexpectedly). Always follow proper procedures for operating on slippery surfaces as described in the owner's manual.

When operating on slippery surfaces such as ice or loose gravel, reduce speed and use extra caution to reduce the chance of skidding or sliding.

Do not operate on excessively slippery surfaces.

Operating Through Water

Operating through deep or fast-flowing water can cause loss of traction, loss of control, overturn or accident. Never

operate in fast-flowing water or in water that exceeds the floor level.

Always follow proper procedures for operating in water as described in the owner's manual.



Wet brakes may have reduced stopping Ability. After leaving water, test the brakes, Apply them lightly several times

while driving slowly. The friction will help dry out the pads.

Safety Warnings

Overloading the Vehicle

Overloading the vehicle or carrying/towing loads may cause changes in stability and handling, which could cause loss of control or an accident.

- Never tow objects or carry loads with this vehicle.
- Never exceed the maximum weight capacity for this vehicle.

Operating a Damaged Vehicle

Operating a damaged vehicle can result in an accident with serious injury or

death. After any overturn or accident, have a qualified service dealer inspect the entire vehicle for possible damage, including (but not limited to) brakes, throttle and steering systems.

Operating on Frozen Bodies of Water

Operating on frozen bodies of water can result in the vehicle and/or riders falling through the ice. Never operate this vehicle on a frozen body of water.

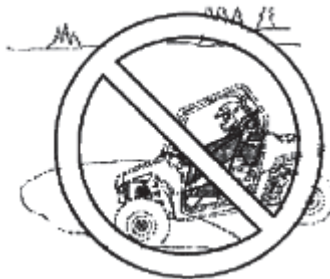

SAFETY

Safety warnings

Handling Gasoline

Gasoline is highly flammable and is explosive under certain conditions. Always exercise extreme caution whenever handling gasoline.

- Never allow a child to refuel or handle gasoline.
- Always stop the engine when refueling.
- Always refuel outdoors or in a well ventilated area.
- Do not smoke or allow open flames or sparks in or near the refueling area or where gasoline is stored.
- Never refuel while a person is in the vehicle.
- Do not over fill the tank. Do not fill the tank neck.
- If gasoline spills on your skin or clothing, immediately wash it off with soap and water and change clothing.
- Turn the fuel valve off whenever the vehicle is stored or parked.

Exposure to Exhaust

Engine exhaust fumes are poisonous and can cause loss of consciousness or death in short time. Never start the engine or let it run in an enclosed area.

Operate this vehicle only outdoors or in well-ventilated areas.

Hot Exhaust Systems

Exhaust system components are very hot during and after use of the vehicle.

Hot components can cause burns and fire. Do not touch hot exhaust system components. Always keep combustible materials away from the exhaust system.

Use caution when traveling through tall grass, especially dry grass. Always inspect the underside of the vehicle and areas near the exhaust system after driving through tall grass, weeds, brush and other tall ground cover. Promptly remove any grass or debris clinging to the vehicle.

SAFETY

Unauthorized Use of the Vehicle

Leaving the keys in the ignition can lead to unauthorized use of the vehicle, Which could result in an accident or overturn. Always remove the ignition key when the vehicle is not in use.

Safety Labels and Locations

Warning labels have been placed on the vehicle for your protection.

Read and follow the instructions on each label carefully. If any of the labels shown in this manual differ from the labels on your vehicle, always read and follow the instructions of the labels on the vehicle.

If an informational or graphic label becomes illegible or comes off, contact your Yours dealer to purchase a replacement. Replacement safety labels are provided by Yours at no charge. The part number is printed on the label.

SAFETY

Safety Labels and Locations

Rear Warning Label

WARNING

Improper vehicle use can result in

SEVERE INJURY or **DEATH**

NEVER allow to be operated:

- without all occupants first viewing and understanding safety video ,and warning labels.
- with more than one passenger.
- on hills steeper than 15 degrees \angle 15° .
- on paved surfaces – pavement may seriously affect handling and control.
- with non–Yours approved accessories – they may seriously affect stability.
- at speeds that are too fast for the operator's skills, the conditions and/ or the terrain.

ALWAYH require operator and passenger to:

- wear seat belts, grab hand holds (passenger) and plant feet firmly on the floor.
- secure cab nets.
- Keep hands and feet inside vehicle.
- avoid quick turns of the steering wheel and driving stunts such as jumps, donuts or power slides.
- reduce speed and use extra caution when carrying a passenger.
- watch for branches or other hazards that could enter vehicle.

WARNING

Operation of this vehicle by children age 16 and under increases the risk of severe injury or death.

NEVER permit children age 16 and under to operate or ride in this vehicle.



FEATUR AND CONTROLS

WARNING

VEHICLE OVERTURN could cause severe injury or death. The cab frame is not designed or intended to provide reliever protection.

TIRE PRESSURE IN PSI (KPa):

Front: 14 psi (97kPa)

Rear: 21 psi (145kPa)

MAXIMUM WEIGHT CAPACITY 300 lbs. (136 KG)

NCLUDES WEIGHT OF OPERATOR, PASSENGER AND ACCESSORIES.

LOCATE AND READ OWNER'S MANUAL. FOLLOW ALL INSTRUCTIONS AND WARNINGS. IF OWNER'S MANUAL IS MISSING, CONTACT A YOURS DEALER FOR A REPLACEMENT.

FEATUR AND CONTROLS

Component Locations

Your (150cc 200cc)vehicle is equipped with cab nets and side guards on both sides of the vehicle. Cab nets and side guards must be used by both operator and passenger at all times. Promptly replace worn or damaged cab nets withnew cab nets, available from your authorized Yours dealer. The vehicle illustrated below is shown without cab nets only to allow component identification. Always use the cab nets and side guards.

250cc 400cc with steel door, steel cab , will be more safe, please always keep the both operator and passenger side doors locked at all times.

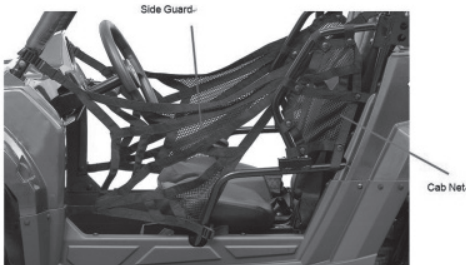
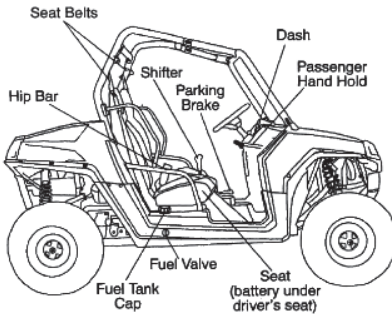

FEATUR AND CONTROLS

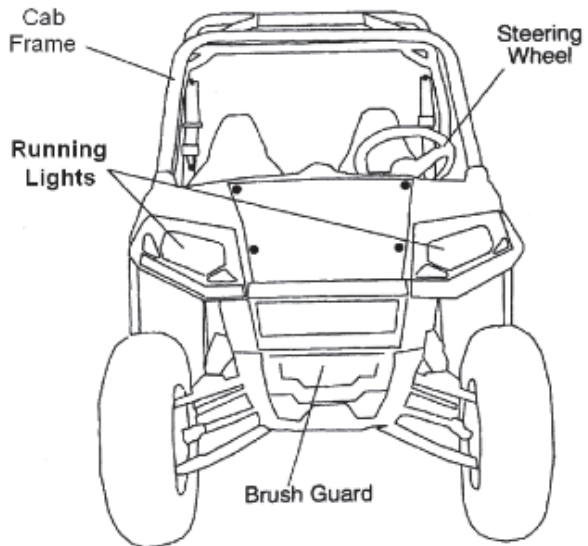
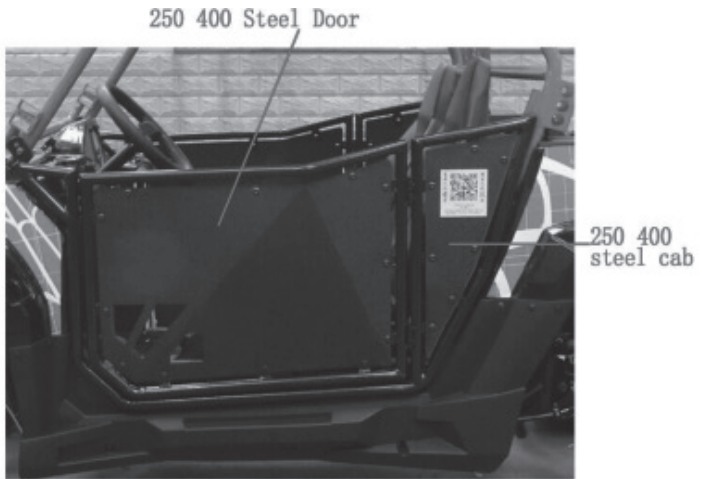

FEATUR AND CONTROLS

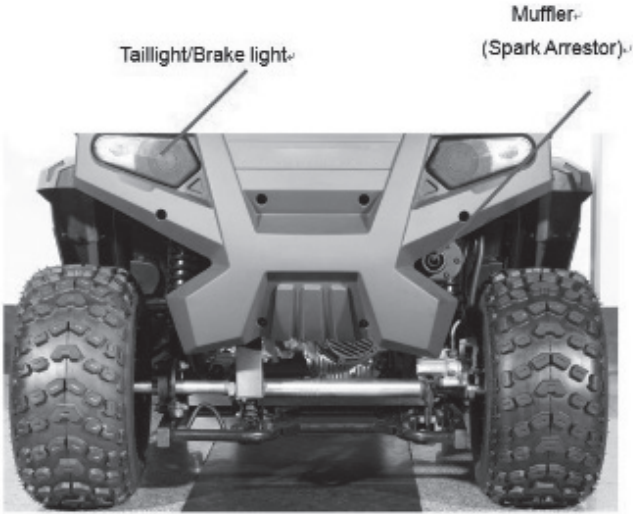

FEATUR AND CONTROLS

Seats

Driver' s Seat Adjustment

- 1.Lift the seat latch lever located under the right front edge of the driver's seat.
2. While holding the lever upward, slide the seat forward or rearward to the desired position, then release the lever.
3. Slide the seat forward and rearward to ensure the latch is engaged. Before operating the vehicle, always make sure both seats are securely installed.

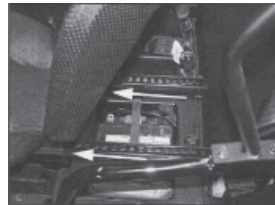

←
Side Seat Forward

Seat Removal

- 1.To remove the driver's seat, lift the seat latch lever.
2. While holding the lever upward, slide the seat completely forward to remove it from the seat mounting rails.
3. Before operating the vehicle, always make sure the driver's seat is installed and securely latched.
4. To remove the passenger seat, remove the two bolts located at the front of the seat mounting rails. Slide the seat forward to remove it from the vehicle. Always reinstall the passenger seat before operating the vehicle. After reinstalling the seat and bolts, torque the nuts to 10 ft. lbs. (13.5 Nm).

FEATUR AND CONTROLS

Steering Wheel

The steering Wheel can be adjusted upward or downward for rider preference.

- 1.Loosen the steering wheel adjustment bolt.
- 2.Mow the steering wheel upward or downward to the desired position.
- 3.Tighten the bolt to 10 ft. lbs. (13.5 Nm).

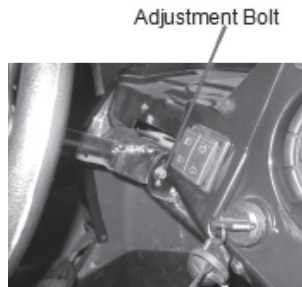

Passenger Hand Hold

Always adjust the hand hold to a comfortable position for your passenger before operating. Make sure the adjustment pin and retainer are securely installed after making adjustments.

- 1.Remove the retainer from the end of the adjustment pin. Remove the pin from the post.
- 2.Slide the post inward or outward to the desired position.
- 3.Reinstall the pin through the mounting bracket hole, through both post adjustment holes, and through the remaining bracket hole.
- 4.Reinstall the retainer to the pin.

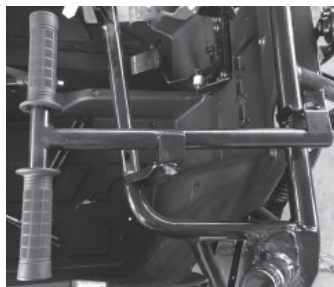

FEATUR AND CONTROLS

Seat Belts

This Yours vehicle is equipped with three–point lap and diagonal seat belts for the operator and passenger. Always make sure the seat belts are secured for both the operator and passenger before riding.

To wear the seat belt properly, followthis procedure:

1. Pull the seat belt latch downward and across your chest toward the buckle at the inner edge of the seat. The belt should fit snugly across your hips and diagonally across your chest. Make sure the belt is not twisted.

Tip: The position of the shoulder strap can be adjusted to the height of the operator.

Have an adult relocate the mounting bolt to a different position, making sure the nut and bolt are tightened securely.

2. Push the latch plate into the buckle until it clicks.
3. Release the strap, it will self–tighten.
4. Press the red release latch on the buckle to release the seat belt.

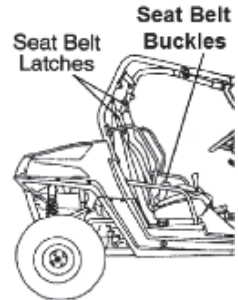

FEATUR AND CONTROLS

Seat Belts

Seat Belt Inspection

Inspect all belts for before each of the vehicle.

1.Push the latch plate into the buckle until it clicks. The latch plate must slide smoothly into the buckle. A click indicates that it's securely latched.

2.Push the red release latch in the middle of the buckle to make sure it releases freely.

3.Pull each seat belt completely out and inspect the full length for any damage, including cuts, wear, fraying or stiffness. If any damage is found, or if the seat belt does not operate properly, have the seat belt system checked and/or replaced by an authorized Yours dealer.

4.To clean dirt or debris from the seat belts, sponge the straps with mild soap and water. Do not use bleach, dye or household detergents.

FEATUR AND CONTROLS

Cab Nets/Side Guards

Riding in this vehicle without using the cab nets and side guards increases the risk of serious injury or death in the event of an accident or overturn.

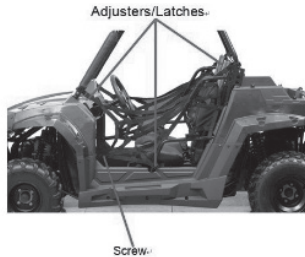

150cc 200cc Cab nets and side guards must be used by both operator and passenger at all times. Make sure all latches are secure before operating the vehicle.

Always inspect cab nets for tightness, wear and damage before each use of the vehicle. Use the strap adjusters to tighten any loose straps. Promptly replace worn or damaged cab nets with new cab nets, available from your authorized Yours dealer.

250cc 400cc with steel door, steel cab , will be more safe, please always keep the both operator and passenger side doors locked at all times.



FEATUR AND CONTROLS

Storage Box

The storage box is attached to the cab frame behind the seats. Use the storage box to carry lightweight items such as water bottles or apparel. Do not carry heavy items in the storage box.



Fuel Cap



Never allow a child to refuel or handle gasoline.

When refueling always use either leaded or unleaded gasoline with a minimum pump octane number of 87 R+M/2 octane. Do not use fuel with ethanol content greater than 10 percent, such as E-85 fuel.



RES: For reserve supply if main supply is exhausted.

The reserve setting allows operation for approximately 7–10 miles (11–16 km). Always refill the gas tank as soon as possible after using the Main supply, Always return the valve to the ON position after refueling.

FEATUR AND CONTROLS

Ignition Switch

The ignition switch is a three–position, key–operated switch. Use the ignition switch to start the engine. See page 45 for starting procedures.

The key can be removed from the switch when it is in the OFF position.

OFF	The engine is off. Electrical circuits are off, except accessory 12V.
ON	Electrical circuits are on. Electrical equipment can be used.
START	Turn the key to the START position to engage the electric starter. The key returns to the ON position when released.

Ignition Switch

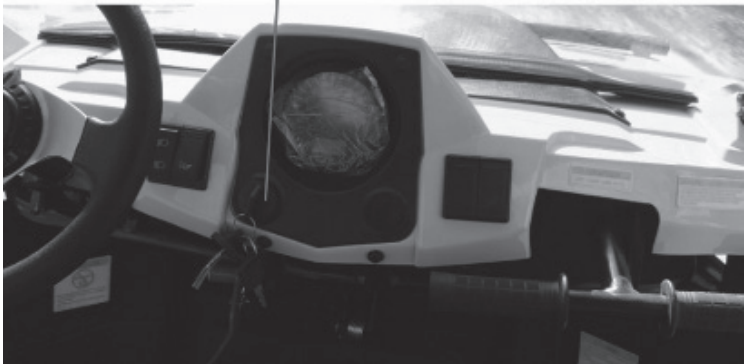

FEATUR AND CONTROLS

Gear Selector

F: Forward

N: Neutral

R: Reverse

The gear selector is located between the seats. To change gears, stop the vehicle, and with the engine idling, move the lever to the desired gear. Do not attempt to shift gears with engine speed above idle or while the vehicle is moving.

Gear Selector



Tip: Maintaining shift linkage adjustment is important to assure proper transmission function. See your dealer if you experience any shifting problems.

NOTICE: Do not attempt to shift the transmission while the vehicle is moving or damage to the transmission could result. Always shift when the vehicle is stationary and the engine is at idle.

Parking Brake

1. Apply the brakes.
2. When the vehicle is fully stopped, pull the parking brake lever rearward as far as possible to set the parking brake.
3. Stop the engine.
4. To release the parking brake, apply the brakes and push the lever toward the passenger seat and forward.

Tip: Always set the parking brake whenever the vehicle is left unattended.

 Operating the vehicle while the parking brake is engaged could cause an accident resulting in serious injury or death. It could also result in driveline or engine damage. Always be sure to disengage the parking brake before operating the vehicle.

FEATUR AND CONTROLS

Brake Pedal

Depress the brake pedal to slow or stop the vehicle. Apply the brakes while starting the engine.

Throttle Pedal

Push the pedal down to increase engine speed. Spring pressure returns the pedal to the rest position when released. Always check that the throttle pedal returns normally before starting the engine.

Make sure there's adequate throttle pedal freeplay. See page 81 for throttle pedal adjustment procedures.



Brake Pedal

Throttle Pedal

FEATUR AND CONTROLS

Speed Control System

The speed of this vehicle is restricted to under 15 MPH (24 km/h) at manufacture, The speed limiting device may be adjusted by supervising when they determine that their child is capable of handling additional speed.

The unrestricted top speed for this model is approximately 25MPH(40km/h).

The adjustable throttle limiting screw is located behind the throttle pedal. Use the following procedure to control how far the throttle opens.

- 1.Loosen the jam nut.
- 2.Turn the screw outward to reduce speed. Turn the screw inward to increase speed.
- 3.Tighten the jam nut after adjusting.



adjusting bolt

! WARNING

Failure to operate the vehicle properly can result in a collision, loss of control, accident or overturn, which may result in serious injury or death. Read and understand all safety warnings outlined in the safety section of this owner's manual.

Vehicle Break-in Period

The break-in period for your new Yours vehicle is defined as the first ten hours of operation, or the time it takes to use the first two full tanks of gasoline.

No single action on your part is as important as a proper break-in period. Careful treatment of a new engine and drive components will result in more efficient performance and longer life for these components. Perform the following procedures carefully.

NOTICE: Excessive heat build-up during the first three hours of operation will damage close-fitted engine parts and drive components. Do not operate at full throttle or high speeds during the first three hours of use. Mixing brands or using a non-recommended oil may cause serious engine damage. Always use the recommended oil. Never substitute or mix oil brands.

OPERATION

Vehicle Break-in Period

Engine and Drivetrain Break-in

- 1.Fill the tank with gasoline. Always exercise extreme caution. whenever handling gasoline. Never allow a child to handle gasoline.
- 2.Cheke the oil level. See page 68. Add the recommended oil as needed to maintain the oil level in the safe operating range.
- 3.Complete the New Operator Driving Procedures outlined on pages 51–52.
- 4.Avoid aggressive use of the brakes. See Brake System Break-in below.
- 5.Vary throttle positions. Do not operate at sustained idle.
- 6.Perform regular checks on fluid levels, controls and areas outlined on the daily pre-ride inspection checklist. See page 47.
- 7.Change the engine oil at 10 hours or one month.
- 8.Adjust and lubricate the drive chain at 10 hours or one month.

Brake System Break-in

Apply only moderate braking force for the first 50 stops. Aggressive or overly forceful braking when the brake system is new could damage brake pads and rotors.

CVT Break-in (Clutches/Belt)

A proper break-in of the clutches and drive belt will ensure a longer life And better performance. Break in the clutches and belt by operating at Slower speeds during the break-in period as recommended. Avoid Aggressive acceleration and high speed operation during the break-in period.

OPERATION

Pre-Ride Inspection

Failure to inspect and verify that the vehicle is in safe operating condition before operating increases the risk of an accident. Always inspect the vehicle before each use to make sure it's in safe operating condition.

Item	Remarks	Page
Brake system/pedal travel	Ensure proper operation	43 83
Brake fluid	Ensure proper level	84
Front suspension	Inspect, lubricate if necessary	67
Rear suspension	Inspect, lubricate if necessary	67
Steering	Ensure free operation	85
Tires	Inspect condition and pressure	31 87
Wheels/fasteners	Inspect, ensure fastener tightness	88
Frame nuts, bolts, fasteners	Inspect, ensure tightness	–
Fuel and oil	Ensure proper levels	46 68
Grass and debris	Remove grass and debris from the vehicle, especially on the underside and near the exhaust system	–
Throttle	Ensure proper operation	81
Indicator lights/switches	Ensure proper operation	–
Air filter, pre-filter	Inspect, clean or replace	78
Daytime running lights	Ensure proper operation	89
Brake light	Ensure proper operation	–
Seat Latches	Move the seats forward and rearward to ensure correct installation	35
Seat Belts	Check length of belt for damage, check latches for proper operation	38
Cab Nets	Check for wear or damage, ensure proper installation	39

OPERATION

Safe Operation Practices

1. Complete the New Operator Driving Procedures outlined on pages 51–52.
2. Do not ride at night or when visibility is poor (rain, fog, dusk). Your vehicle doesn't have lights that are designed for driving in these conditions.
3. Never tow objects or carry loads with this vehicle.
4. Engine exhaust fumes are poisonous. Never start the engine or let it run in an enclosed area. Never allow a child to handle gasoline.
5. Never install accessories not approved by Yours for use on this vehicle,
6. Ride this vehicle only in areas permitted by a supervising adult. Never operate the vehicle on pavement or on any public street, road Or highway, including dirt and gravel roads.
7. Drive in a manner appropriate for your skills and operating conditions. Never operate at excessive speeds. DO NOT attempt to do power slides, “donuts” , jumps or other driving stunts. Keep both hands on the steering wheel at all times.
8. Never consume alcohol or drugs before or while operating this vehicle.
9. Always use the size and type of tires specified for your vehicle.
Always maintain proper tire pressure.
10. Never operate a damaged vehicle. After any overturn or accident, have a qualified service dealer inspect the entire machine for possible damage.
11. Never operate the vehicle on a frozen body of water.
12. Do not touch hot exhaust system components. Always keep combustible materials away from the exhaust system.
13. Always remove the ignition key when the vehicle is not in use to prevent unauthorized use.

Starting the Engine

1. Turn the fuel valve on.
2. Sit in the driver's seat and fasten the seat belt.
3. Secure the cab nets.
4. Place the transmission in neutral. Set the parking brake.
5. Apply the brakes.
6. Do not press the throttle pedal while starting the engine.
7. Turn the ignition key past the ON/RUN position to START. Engage the starter for a maximum of five seconds. Release the key when the engine starts.

NOTICE: Operating the vehicle immediately after starting could cause engine damage. Allow the engine to warm up for several minutes before operating the vehicle.

8. If the engine does not start within five seconds, return the ignition switch to the OFF position and wait five seconds. Repeat steps 7 and 8 until the engine starts.

If your vehicle has Hand-choke:

Tip: If a warm engine has cooled to a point where it does not readily start, intermittent use of the choke (pulled half way out) may be necessary. If the engine is over-choked when warm, depress the throttle lever fully while cranking to aid in starting. Release the throttle lever immediately after the engine starts. If the engine does not start and all conditions are favorable, change the spark plug and try again.

9. Vary the engine RPM slightly with the throttle to aid in warm-up until the engine idles smoothly.
10. Release the parking brake before driving.

OPERATION

Stopping the Engine

1. Release the throttle pedal completely and brake to a complete stop.
2. Place the transmission in neutral.
3. Set the parking brake.
4. Stop the engine.
5. Turn the fuel valve off.

Braking

1. Release the throttle pedal completely. (When the throttle pedal is released completely and engine speed slows to near idle, the vehicle has engine braking.)
2. Press on the brake pedal evenly and firmly. Practice starting and stopping (using the brakes) until you're familiar with the controls.

Parking the Vehicle

1. Stop the vehicle on a level surface. When parking inside a garage or other structure, be sure that the structure is well ventilated and that the vehicle is not close to any source of flame or sparks, including any appliance with pilot lights.
2. Place the transmission in neutral.
3. Set the parking brake.
4. Stop the engine.
5. Turn the fuel valve off.
6. Remove the ignition key to prevent unauthorized use.

New Operator Driving Procedures

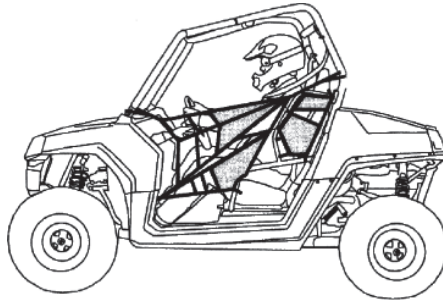

1. Read and understand the owner's manual and all warning and instruction labels before operating this vehicle.
2. Watch the instructional video with the supervising adult.
3. Review the section of this owner's manual about starting the engine stopping the engine, braking and parking (pages 50).
4. Perform the pre-ride inspection (page 47).
5. Wear appropriate riding gear, including an approved helmet and protection (goggles or face shield).
6. Select a level open area to practice driving. Make sure you have adult supervision and permission to drive in this area.
7. Sit in the driver's seat and fasten the seat belt.
8. Do not operate or ride in this vehicle if the clearance between the top of your helmet and the overhead cab frame is less than 2 inches (5 cm).

(continued on next page)

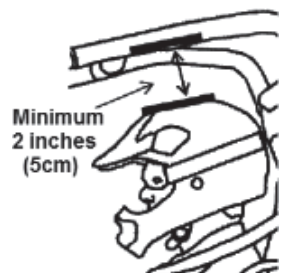

OPERATION

New Operator Driving Procedures

9. Do not carry a passenger until you have at least four hours of driving experience with this vehicle. See page 53.

10. Make sure all cab nets and side guards are properly secured.

11. Set the transmission in neutral.

12. Place the transmission in neutral.

13. Start the engine.

14. Apply the brakes and shift into gear.

15. Release the parking brake.

16. Check your surroundings. Make sure the area is clear of people and obstacles.

17. Keeping both hands on the steering wheel, slowly release the brakes and press the throttle with your right foot to begin driving.

18. Drive slowly at first. Practice starting, stopping, turning, using the throttle and brakes and driving in reverse. Learn how the vehicle handles when making both left and right turns at a slow speed.

19. Increase speed only after mastering all maneuvers at a slow speed.

20. After you become skilled at making turns and begin to operate at faster speeds, follow these precautions:

- Avoid sharp turns. Make turns gradually.
- Never turn while applying heavy throttle.
- Never turn the steering wheel abruptly.

● Operate at speeds appropriate for your skills, the conditions and the terrain.

● DO NOT attempt to do power slides, "donuts", jumps or other driving stunts.

OPERATION

Driving with a Passenger

1. Complete the New Operator Driving Procedures outlined on pages 51–52.
2. Perform the pre-ride inspection. See page 47.
3. Do not carry a passenger until you have at least four hours of driving experience with this vehicle.
4. Never operate with a passenger age 16 and under. Make sure the passenger is tall enough to comfortably and safely sit in the passenger seat with the seat belt secured, put both feet on the floor and grasp the hand holds.
5. Make sure the passenger has at least 2 inches (5 cm) of clearance between his helmet and the top of the cab frame.
6. Never carry more than one passenger in this vehicle.
7. Never allow a passenger to ride on the back of the vehicle. Allow a passenger to ride only in the passenger seat.
8. Make sure the passenger is wearing appropriate riding gear, including an approved helmet and eye protection. See page 14.
9. Make sure the passenger secures the seat belt.
10. Tell your passenger to always keep hands and feet inside the vehicle at all times.
11. Make sure all cab nets and side guards are properly secured.
12. Drive slowly. Vehicle handling may change with a passenger on board. Always travel at a speed appropriate for your skills, your passenger's skills, and operating conditions. Avoid unexpected or aggressive maneuvers that could cause discomfort or injury to a passenger.
13. Always follow all operating guidelines as outlined on safety label and in this manual.



OPERATION

Driving on Slippery Surfaces

When driving on slippery surfaces such as wet trails, loose gravel, sand or ice, be alert for the possibility of skidding and sliding.

Skidding or sliding can cause loss of control or overturn, especially if tires regain traction unexpectedly. When operating on slippery surfaces such as ice or loose gravel, slow down and use extra caution to help prevent skidding or sliding. Always use extra caution when operating on sand or on rough, slippery or loose terrain. Do not operate on excessively rough, slippery or loose terrain.

Follow these precautions when driving in slippery conditions:

1. Slow down before entering slippery areas.
2. Be alert, watch the path ahead and avoid quick turns, which can cause skids.
3. Correct a skid by turning the steering wheel in the direction of the skid. Never apply the brakes during a skid.

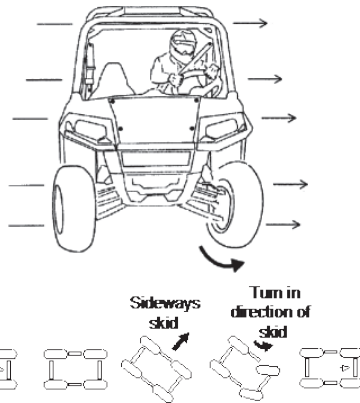

Driving Uphill

Whenever traveling uphill, follow these precautions:

1. Always check the terrain carefully before ascending a hill.
2. Avoid steep hills (15° maximum).
3. Drive straight uphill.
4. Never climb hills with excessively slippery or loose surfaces.
5. Drive at a steady rate of speed. Never press the throttle suddenly.
6. Avoid unnecessary changes in speed or direction.
7. Never go over the crest of a hill at a high speed. An obstacle, a sharp drop, or another vehicle or person could be on the other side of hill.
8. If the vehicle stalls while climbing a hill, apply the brakes. Place transmission in reverse and slowly allow the vehicle to roll straight downhill while applying the brakes lightly to control speed.

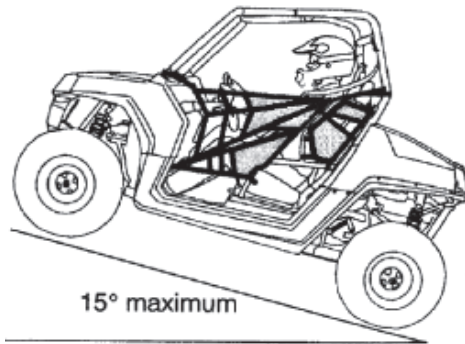

OPERATION

Driving on a Sidehill (Sidehilling)

Driving on a sidehill is not recommended. Driving on a sidehill improperly cause loss of control or overturn.

If crossing a hill is unavoidable, follow these precautions:

1. Drive slowly and use extreme caution.
2. If the vehicle begins to overturn, or if it feels as if it may overturn, immediately turn downhill.
3. Avoid obstacles and changes in terrain that may lower or raise one side the vehicle or cause the vehicle to slide.
4. If the vehicle begins to slide downhill, immediately turn downhill to stop the slide.

Driving Downhill

Whenever driving down a hill, follow these precautions:

1. Avoid steep hills (15° maximum).
2. Slow down. Never travel down a hill at high speed.
3. Always check the terrain carefully before driving down a hill.
4. Always drive down a hill with the transmission in forward gear.
Never "coast" or drive down a hill with the transmission in neutral.
5. Avoid driving down a hill at an angle, which would cause the vehicle lean sharply to one side. Always drive straight downhill.
6. Apply the brakes lightly to keep speed slow.

Driving Through Water

Your vehicle can drive through shallow water. Make sure the water is no deeper than the floor of the vehicle. Follow these precautions when driving through water:

1. Check water depth. Never drive through water that is deeper than the floor level.
2. After driving through water, test the brakes. Apply them lightly several times while driving slowly. The friction will help dry out the pads.

NOTICE: Major engine damage can result if the vehicle is not thoroughly inspected after operation in water. Perform the services outlined in maintenance chart. See page 64. Give special attention to engine transmission oil and all grease fittings.

If your vehicle is operated in water deeper than the floor level, take to your dealer for service before starting the engine. If it's impossible to bring the vehicle to your dealer before starting the engine, perform the service outlined on page 90, and take the vehicle to your dealer as soon as possible.

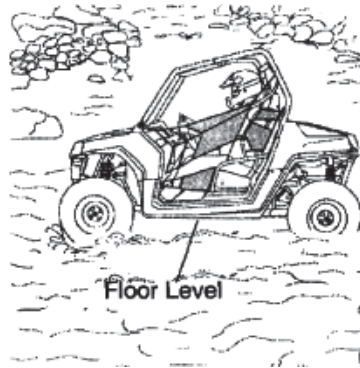

OPERATION

Driving Over Obstacles

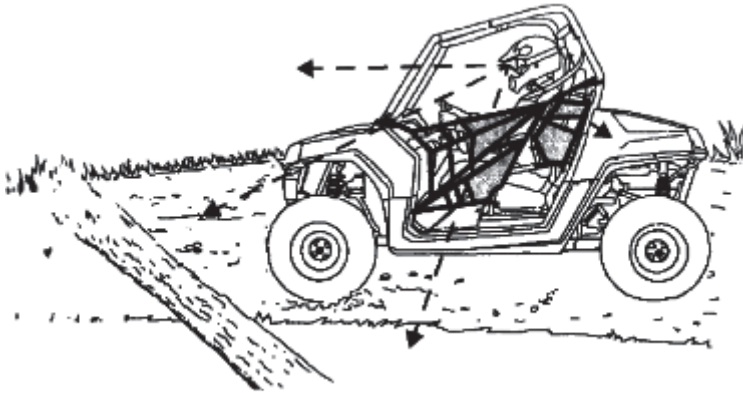

Follow these precautions when driving over obstacles:

1. Always check for obstacles before driving in a new area.
2. Look ahead and watch the terrain. Always be alert for hazards such as logs, rocks and low hanging branches.
3. Drive slowly and use extra caution when driving on unfamiliar terrain.
Obstacles are not always clearly visible.
4. Do not drive over large obstacles such as rocks and fallen trees. If it's unavoidable, use extreme caution and drive slowly.
5. Always have a passenger dismount and move away from the vehicle before driving over an obstacle that could cause an overturn.

Driving in Reverse



Follow these precautions when driving in reverse:

1. Always check for obstacles or people behind the vehicle.
2. Apply the throttle lightly. Never apply the throttle suddenly.
3. Back slowly.
4. Apply the brakes lightly for stopping.
5. Avoid making sharp turns.

OPERATION

Parking on an Incline

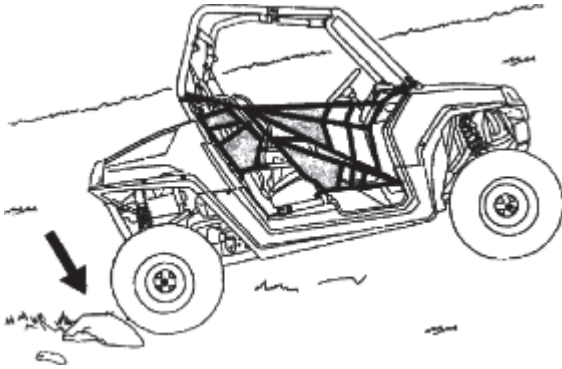

A rolling vehicle can result in serious injury. Avoid parking on an Incline. If parking on an incline is unavoidable, follow these precautions:

- 1.Place the transmission in neutral.
- 2.Set the parking brake.
- 3.Stop the engine.
- 4.Turn the fuel valve off.
- 5.Always block the rear wheels on the downhill side.

EMISSION CONTROL SYSTEMS

Noise Emission Control System

Do not modify the engine, intake or exhaust components, as doing may affect compliance with U.S.A. EPA noise control requirement, CFR 205) and local noise level requirements.

Operation on Public Lands in the U.S.A.

Yours vehicle has a spark arrestor that was tested and qualified to be in accordance with the USFS standard 5100–1c. Federal law requires that this spark arrestor be installed and functional when the vehicle is operated on public lands.

Operation of off–road vehicles on public lands in the U.S.A. is regulated by 43 CFR 420. Violations are subject to monetary penalties.

Crankcase Emission Control System

This engine is equipped with a closed crankcase system. Blow–by gases are forced back to the combustion chamber by the intake system. All exhaust gases exit through the exhaust system.

Exhaust Emission Control System

The emissions from the exhaust of this vehicle are controlled by engine design, including factory–set fuel delivery and ignition. The engine and related components must be maintained at Yours specifications to achieve optimal performance.

Engine idle speed is the only adjustment Yours recommends that you perform. Any other adjustments should be performed by an authorized Yours dealer.

The emissions label is located on the frame behind the right front wheel.

Electromagnetic Interference

This spark ignition system complies with Canadian ICES–002.

This vehicle complies with the EMC requirements of European directives 97/24/EC and 2004/108/EC.

MAINTENANCE

Periodic Maintenance Chart

Careful periodic maintenance will help keep your vehicle in the safest, most reliable condition. Inspection, adjustment and lubrication of important components are explained in the periodic maintenance chart.

Inspect, clean, lubricate, adjust and replace parts as necessary. When inspection reveals the need for replacement parts, use genuine Yours parts available from your Yours dealer.

Record maintenance and service in the Maintenance Log beginning on page 116.

Service and adjustments are important for proper vehicle operation. If You' re not familiar with safe service and adjustment procedures, have a qualified dealer perform these operations.

Maintenance intervals in the following chart are based upon average riding conditions and an average vehicle speed of approximately ten (10) miles per hour. Vehicles subjected to severe use must be inspected and serviced more frequently.

Severe Use Definition

- Frequent immersion in mud, water or sand
- Racing or race–style high RPM use
- Prolonged low speed operation
- Extended idle
- Short trip cold weather operation

Pay special attention to the oil level. A rise in oil level during cold weather can indicate contaminants collecting in the oil sump or crankcase. Change oil immediately if the oil level begins to rise. Monitor the oil level, and if it continues to rise, discontinue use and determine the cause see your dealer.

MAINTENANCE

Periodic Maintenance Chart

! WARNING

Improperly performing the procedures marked with a ■ could result in component failure and lead to serious injury or death. Have an authorized Yours dealer perform these services.

Maintenance Chart Key

▲ Perform these operations more often for vehicles subjected to severe use.

E Emission-related service (Failure to conduct this maintenance will not void the emissions warranty but may affect emissions.)

■ Have an authorized Yours dealer perform these services.

MAINTENANCE

Periodic Maintenance Chart

Perform all services at whichever maintenance interval is reached first.

Item		Maintenance Interval (whichever comes first)			Remarks
		Hours	Calendar	Miles (Km)	
■	Steering	-	Daily	-	Check each day before driving the vehicle. Make adjustments as needed. See the Pre-Ride Checklist on page 47.
▲	Front suspension	-	Daily	-	
▲	Rear suspension	-	Daily	-	
	Tires	-	Daily	-	
▲	Brake fluid level	-	Daily	-	
▲	Brake pedal travel	-	Daily	-	
	Brake system	-	Daily	-	
	Wheels/fasteners	-	Daily	-	
	Frame fasteners	-	Daily	-	
▲	Engine oil level	-	Daily	-	
▲ E	Air filter, pre-filter	-	Daily	-	Inspect; clean often; replace as needed
	Daytime running lights/taillight	-	Daily	-	Check operation
	Drive chain	-	Daily	-	Inspect daily; adjust and lubricate if needed
	CVT housing (if equipped)	-	Weekly	-	Drain water as needed, check often if driving wet conditions
▲ E	Air filter, main element	-	Weekly	100(160)	Inspect; replace as needed
▲ ■	Brake pad wear	10	Monthly	100(160)	Inspect periodically
	Idle speed		Monthly	100(160)	Check; adjust as needed
■ E	Choke	10	Monthly	-	Check for proper operation; see dealer for adjustments
▲	Engine oil change (break-in)	10 10	1M	-	Perform a break-in oil change at one month
	Drive chain(break-in)	10	1M	250(400)	Adjust and lubricate
	Battery	25	Monthly		Check terminals; clean; test
▲	Main gearcase oil	25	Monthly	25(400)	Inspect level; change yearly

MAINTENANCE

▲ Perform these procedures more often for vehicles subjected to severe use.

E Emission-Related Service

■ Have an authorized Yours dealer perform these services.

Periodic Maintenance Chart

	Item	Maintenance Interval (whichever comes first)			Remarks
		Hours	Calendar	Miles (Km)	
▲ E	Engine breather	25	Monthly	150 (250)	Inspect; replace if necessary
▲	Engine oil change	30	6M	300 (480)	Perform a break-in oil change at one month
▲	General lubrication	50	3M	500(800)	Lubricate all fittings, pivots, cables, etc.
■ E	Throttle cable/ ETC switch	50	6M	300 (480)	Inspect; adjust; lubricate; replace if necessary
	Carburetor float	50	6M	500(800)	Drain bowl periodically and prior to storage
■ E	Choke cable	50	6M	500(800)	Inspect; adjust; lubricate; replace if necessary
E	Carburetor air intake ducts/flange	50	6M	500(800)	Inspect duct for proper sealing/air leaks
	Shift Linkage	50	6M	500(800)	Inspect, lubricate, adjust
■	Steering	50	6M	500(800)	Lubricate
▲	Front Suspension	50	6M	500(800)	Lubricate
▲	Rear Suspension	50	6M	500(800)	Lubricate
■ E	Fuel system/filter	100	12M	600(1000)	Check for leaks at tank cap, lines, fuel valve, filter, pump, carburetor; replace lines every two years
▲ E	Spark plug	100	12M	600 (1000)	Inspect; replace as needed

▲ Perform these procedures more often for vehicles subjected to severe use.

E Emission-Related Service

■ Have an authorized Yours dealer perform these services.

MAINTENANCE

Periodic Maintenance Chart

Item		Maintenance Interval (whichever comes first)			Remarks
		Hours	Calendar	Miles (Km)	
▲	Engine mounts	100	12M	1000(1600)	Inspect
	Exhaust muffler/pipe	100	12M	1000(1600)	Inspect
■	Ignition timing	100	12M	1000(1600)	Inspect
▲	Wiring	100	12M	1000(1600)	Inspect for wear, routing, security; apply dielectric grease to connectors subjected to water, mud, etc.
■	Clutches (drive and driven)	100	12M	1000(1600)	Inspect; clean; replace worn parts
	Drive belt	100	12M	1000(1600)	Inspect; replace as needed
■	Front wheel bearings	100	12M	1000(1600)	Inspect; replace as needed
■	Brake fluid	200	24	2000(3200)	Change every two years
	Spark arrestor	300	36M	3000 (4800)	Clean out
	Idle speed	-			Adjust as needed
■	Toe adjustment	-			Inspect periodically; adjust when parts are replaced

▲ Perform these procedures more often for vehicles subjected to severe use.

E Emission-Related Service

■ Have an authorized Yours dealer perform these services.

MAINTENANCE

Lubrication Recommendations

Check and lubricate all components at the intervals outlined in the Periodic Maintenance Chart beginning on page 58, or more often under severe use, such as wet or dusty conditions. Items not listed in the chart should be lubricated at the general lubrication interval.

Item	Lube	Method
Engine Oil	Yours Synthetic Youth Oil or Synthetic SAE 40	See page 69.
Brake Fluid	DOT 4	See page 84.
Transmission Oil(Main Gearcase)	Premium AGL Synthetic Gearcase Lube	See page 70.
150 200 Drive Chain	Yours Chain/shaft Lube or SAE 80/90	See page 72.
250 400 e-drive shaft		
A-Arm Pivots	Yours All Season Premium Grease or grease conforming to NLGL No.2	Grease at general lubrication interval, also after washing vehicle or driving in water.
▲ Steering Arm Pivots		

▲ Perform these procedures more often for vehicles subjected to severe use

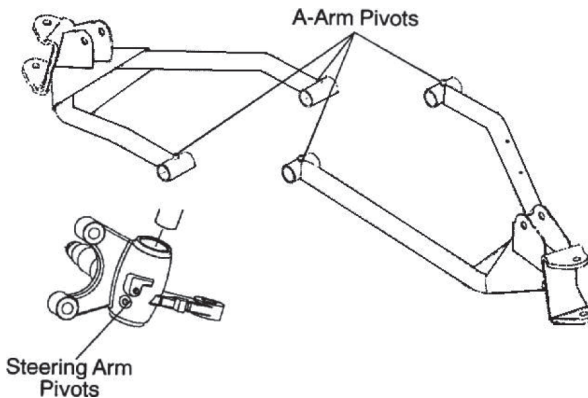

MAINTENANCE

Engine Oil

Always check and change the engine oil at the intervals outlined in the Periodic Maintenance Chart beginning on page 64. Oil may need to be changed more frequently if Yours oil is not used. Do not use automotive oil. See page 118 for the part numbers of Yours products.

Oil Recommendations

These Operating Conditions	Use This Recommended Oil
Outside air temperature is above 32 °F /0°C	Yours Synthetic Youth Oil(or Synthetic SAE40)
Outside air temperature is below 32 °F /0°C	Semi-Synthetic 20W-40

NOTICE: Mixing brands or using a non-recommended oil may cause serious engine damage. Always use the recommended oil. Never substitute or mix oil brands.

Oil Check

Maintain the oil level within the safe range on the dipstick. Do not overfill.

1. Position the vehicle on a level surface.
2. Remove the dipstick. Wipe it dry with a clean cloth.
3. Reinstall the dipstick completely.
4. Remove the dipstick and check the oil level.

Tip: A rising oil level between checks in cool weather driving can indicate contaminants such as gas or moisture collecting in the crankcase.

If the oil level is over the full/safe mark, change the oil immediately.

5. Add the recommended oil as needed.
6. Reinstall 150/200/250 the dipstick. 400cc you can check the tank dip hole.

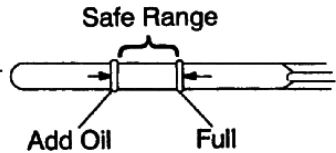

Engine Oil

Oil Change

1. Position the vehicle on a level surface. Set the parking brake.
2. Clean the area around the pre-filter plug.
3. Start the engine. Allow it to idle for two to three minutes.
4. Stop the engine.



Hot oil can cause burns to skin. Do not allow hot oil to contact skin.

5. Place a drain pan under the engine crankcase.

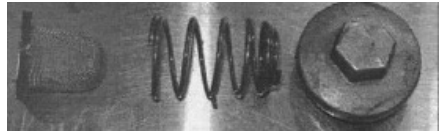

6. Remove the pre-filter plug.

Allow the oil to drain completely.

7. Wash the oil pre-filter screen with solvent to remove debris. Allow the screen to air dry.
8. Clean the pre-filter plug. Install a new sealing washer on the plug. The sealing surfaces on the plug and crankcase should be clean and free of burrs, nicks or scratches.
9. Reassemble the pre-filter screen and spring to the pre-filter plug.
10. Reinstall the pre-filter drain plug. Torque to 11 ft. lbs. (15 Nm).
11. Remove the dipstick. Add 37 oz. (1.1 liters) of the recommended oil. Do not overfill. See the specifications section beginning on page 97 for capacities.
12. Reinstall the dipstick.
13. Start the engine. Allow it to idle for one to two minutes.
14. Stop the engine and inspect for leaks.
15. Check the oil level. Add oil as needed to bring the level to the upper mark on the dipstick.
16. Dispose of used oil properly.

MAINTENANCE

Transmission (Main Gearcase)

Always check and change the fluid at the intervals outlined in the Periodic Maintenance Chart beginning on page 64. Yours recommends the use of Premium AGL Synthetic Gearcase Fluid for this vehicle.

Fluid Check

The 150/200/250f fill plug is located on the rear of the Gearcase. Access the fill plug through the left rear wheel well. Maintain the fluid level at the bottom of the fill plug hole.

- 1.Position the vehicle on a level surface.
- 2.Remove the fill plug.
- 3.Check the fluid level.
- 4.Add the recommended fluid as needed.
- 5.Reinstall the fill plug.

Fill Plug

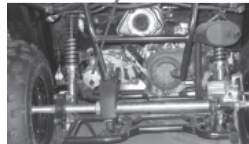

400CC Fill Plug

Fluid Change

The drain plug is located on the bottom of the gearcase.

1. Remove the fill plug.
- 2.Place a drain pan under the drain plug.
- 3.Remove the drain plug. Allow the fluid to drain completely.
- 4.Clean the drain plug.
- 5.Reinstall the drain plug with a new o-ring. Torque to 11ft. lbs. (15Nm).
- 6.Add 20.3 oz. (600 ml) of the recommended fluid to the fill hole.

Maintain the fluid level at the bottom of the fill plug hole. Do not overfill.

MAINTENANCE

- 7.Reinstall the fill plug.
- 8.Check for leaks.
- 9.Discard used fluid properly.

MAINTENANCE

Drive Chain Lubrication

Lubricate the drive chain with Yours chain spray lube or an approved chain lube at the general lubrication interval specified in the Periodic Maintenance Chart beginning on page 64. Lubricate more often under severe use, such as in dirty or wet conditions. See page 118 for the part numbers of Yours products.

NOTICE: Washing the drive chain with a high pressure washer or gasoline can cause premature wear and drive chain failure. Don't use a high pressure washer or gasoline to clean the drive chain.

Adjusting or operating the vehicle with improper rear drive chain slack can result in severe damage to the transmission and drive components. Always make sure the slack is within the stated specifications.

Drive Chain Slack

1. Check the amount of chain slack by moving the vehicle slightly forward to gain slack at the top side of the chain.
2. Raise the rear of the vehicle and support securely under the mainframe. Allow the swing arm to hang at full shock extension without touching the ground. This establishes the tightest chain position.
3. Pull down on the chain tensioner to move it out of the way, then measure chain slack. It should have 1/4"–1/2" (6–12 mm) deflection.
4. If the chain needs adjustment, use the procedure on page 68.

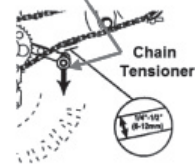

MAINTENANCE

Drive Chain Slack Adjustment (For 150/200)

1. Loosen the four rear housing mount bolts (two on each side).
2. Loosen the chain adjuster lock nuts.
3. Turn the chain adjusters clockwise to 1/4"– 1/2" (6–12 mm) deflection.
4. Tighten the chain adjuster lock nuts to 18 ft. lbs. (25 Nm). Hold the adjuster stud securely while tightening the nut to avoid breaking tile stud.
5. Tighten the four rear housing mount bolts to 43 ft. lbs. (60 Nm).

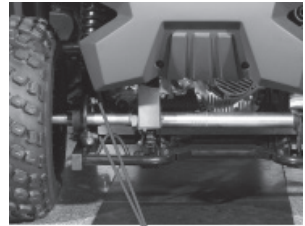

Housing Mount Bolts

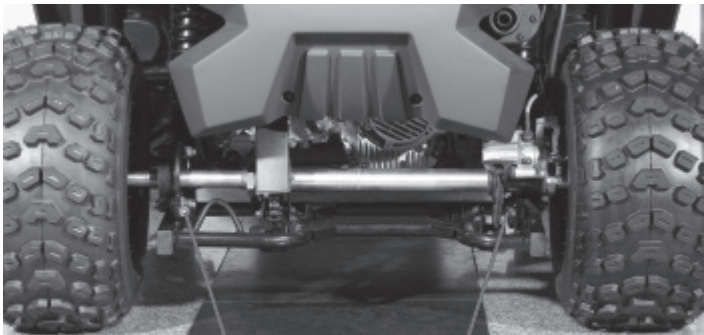

Chain Adjusters

MAINTENANCE

Spark Plugs

Spark Plug Gap/Torque

Electrode Gap	New Plug Torque	Used Plug Torque
0.6–0.7 mm	9–11 ft. lbs. (12–15 Nm)	17–20 ft. lbs. (23–27 Nm)

NOTICE: Using non-recommended spark plugs can result in serious engine damage. Always use Yours-recommended spark plugs. Refer to the specifications section beginning on page 104.

Spark plug condition is indicative of engine operation. The spark plug firing end condition should be read after the engine is warmed up and the vehicle is driven at higher speeds. Immediately check the spark plug for correct color. See page 75.



A hot exhaust system and engine can cause burns. Wear protective gloves when removing a spark plug for inspection.

Spark Plugs

Spark Plug Gap/Torque

Normal Plug

The normal insulator tip is gray, tan or light brown. There will be few Combustion deposits. The electrodes are not burned or eroded. This indicates the proper type and heat range for the engine and the service.

lip: The tip should not be white. A white insulator tip indicates overheating, caused by use of an improper spark plug or incorrect throttle body adjustments.

Wet Fouled Plug

The wet fouled insulator tip is black. A damp oil film covers the firing end. There may be a carbon layer over the entire nose. Generally, the electrodes are not worn. General causes of fouling are excessive oil, use of non-recommended oil, improper use of the choke, or incorrect throttle body/carburetor adjustments.

Spark Plug Removal and Replacement

1. Remove the spark plug cap.
2. Using the spark plug wrench provided in the tool kit, remove the plug by rotating it counter-clockwise.
3. Reverse the procedure for spark plug installation.
Torque to specification.
See page 69.

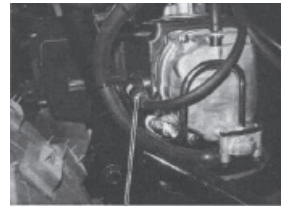

Spark Plug
(right rear wheel well)



400cc

MAINTENANCE

Constant Variable Transmission (CVT) System

! WARNING

Failure to comply with the instructions in this warning can result in severe injury or death.

Do not modify any component of the CVT system. Doing so may reduce its strength so that a failure may occur at a high speed. The CVT system has been precision balanced. Any modification will cause the system to be out of balance, creating vibration and additional loads on components.

The CVT system rotates at high speeds, creating large amounts of force on clutch components. Extensive engineering and testing has been conducted to ensure the safety of this product. However, as the owner, you have the following responsibilities to make sure this system remains safe:

- Always follow all recommended maintenance procedures. See your dealer as outlined in the owner's manual.
- This CVT system is intended for use on Yours products only. Do not install in any other product.
- Always make sure the CVT housing is securely in place during operation.

CVT Drying

There may be some instances when water is accidentally ingested into the CVT system. Use the following instructions to dry it out before operating.

The drain plug is located on the bottom of the CVT cover.

1. Remove the drain plug. Allow the water to drain. Reinstall the drain plug.
2. Shift the transmission to neutral. Set the parking brake.
3. Start the engine. Apply varying throttle for 10–15 seconds to expel the moisture and air—dry the belt and clutches. Do not hold the throttle wide open for more than 10 seconds.

MAINTENANCE

4. Allow the engine RPM to settle to idle speed.
5. Test for belt slippage. If the belt slips, repeat the process.
6. Take the vehicle to your dealer for service as soon as possible.

NOTICE: Exposure to salt water will cause corrosion to metal components. If your vehicle is operated in salt water areas, rinse it off frequently with fresh water.

MAINTENANCE

Filter Systems

Air Filter

Always change the air filter at the intervals outlined in the Periodic Maintenance Chart beginning on page 64. Access the air box through the access cover on the forward surface of the rear bodypanel

1. Move or remove the storage bag.
2. Remove the four (4) access cover fasteners to remove the access cover.
3. Release the air box cover spring clips and remove the cover.
4. Remove the foam air filter.

Wash the foam filter in warm soapy water, then rinse and let dry. If the filter is damaged,

install a new foam filter.

5. Apply a commercially available foam filter lubricant to the foam filter.
6. Clean away any oil or sediments in the air box.
7. Reinstall the filter and air box cover.

Secure the clips.

NOTICE: Never operate the vehicle with the filter element removed, Dirt will enter the engine, causing rapid wear and severe damage to the engine.

8. Reinstall the access cover, and storage bag.



Access Cover

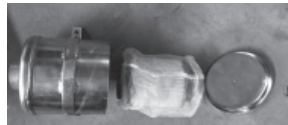

Spark Arrestor

! WARNING

Failure to heed the following warnings while servicing the spark arrestor could result in serious injury or death.

- Do not perform service on the spark arrestor while the system is hot. Allow components to cool sufficiently before proceeding.
- Wear eye protection and gloves.
- Never run the engine in an enclosed area. Exhaust contains poisonous carbon monoxide gas.

To remove accumulated carbon, clean the spark arrestor at the intervals recommended in the Periodic Maintenance Chart beginning on page 64.

1. Remove the six bolts and remove the arrestor from the end of the muffler.
2. Use a non-synthetic brush to clean the arrestor screen. A synthetic brush may melt if components are warm. If necessary, blow debris from the screen with compressed air.
3. Inspect the screen for wear and damage. Replace the arrestor if damage is found.
4. Reinstall the arrestor.
5. Torque the bolts to 7 ft. lbs. (9.5 Nm).

MAINTENANCE

Throttle System

! WARNING

Failure to check or maintain proper operation of the throttle system can result in an accident and lead to serious injury or death if the throttle pedal sticks during operation.

Never start or operate this vehicle if it has a sticking or improperly operating throttle pedal.

Immediately contact your dealer for service if throttle problems arise.

Always check the pedal for free movement and return before starting the engine and occasionally during operation.

Throttle Freeplay

If the throttle pedal has excessive play due to cable stretch or misadjustment, it will cause a delay in throttle response, especially at low engine speed. The throttle may also not open fully. If the throttle

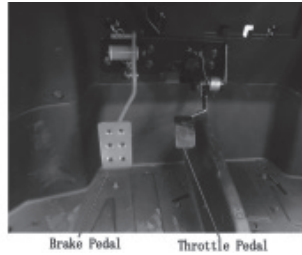

pedal has no freeplay, the throttle may be hard to control, and the idle speed may be erratic.

Check the throttle pedal freeplay at the intervals outlined in the Periodic Maintenance Chart beginning on page 64. Adjust the freeplay if necessary.

Throttle Freeplay Inspection

1. Place the transmission in neutral. Set the parking brake.
2. Start the engine. Allow it to warm up thoroughly.
3. Measure the distance the throttle pedal moves before the engine begins to pick up speed. Freeplay should be 1/16 to 1/8 inches (1.5–3 mm).

Throttle System

Throttle Freeplay Adjustment

Access the throttle cable adjuster through the right front wheel well.

1. Slide the cable adjuster boot off the cable adjuster.
2. Squeeze the end of the rubber boot and slide it far enough to expose the end of the inline cable adjuster.
3. Loosen the adjuster lock nut.
4. Move the cable adjuster until 1/16" to 1/8" (1.5–3mm) of freeplay is achieved at the throttle pedal. See page 80. While adjusting, lightly flip the throttle pedal up and down.
5. Tighten the lock nut.
6. Apply a small amount of grease to the inside of the boot and slide it over the cable adjuster to its original position.

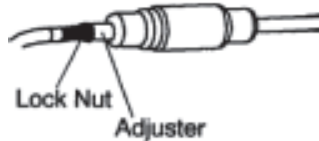
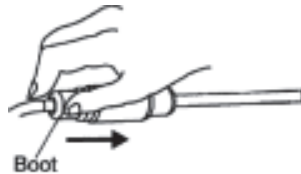

MAINTENANCE

Carburetor

Your vehicle is calibrated at the factory for optimal performance at altitudes ranging from zero to 6,000 feet (1800 m) and temperatures of +40 degrees F. (4 degrees C.) or higher. Above 6000 feet (1800 m) the engine air/fuel mixture becomes overly rich and the engine loses approximately 3% of its power for each 1000-foot (304.8 in) increase in elevation. Although this power cannot be regained, adjustments to the carburetor and drive system can be made to allow more efficient operation.

Optional jets, available from your Yours dealer, are required for operation above 6,000 feet and temperatures below +40 degrees F. (4 degrees C.)
Tip: Continuous operation of the engine without proper jetting when required can cause poor performance, overheating or engine damage. See your Yours dealer for more information about jetting the vehicle for conditions in your area.

Carburetor/Engine Idle RPM Adjustment

If the engine idle speed is not satisfactory, and all other conditions are favorable, the carburetor can be adjusted.

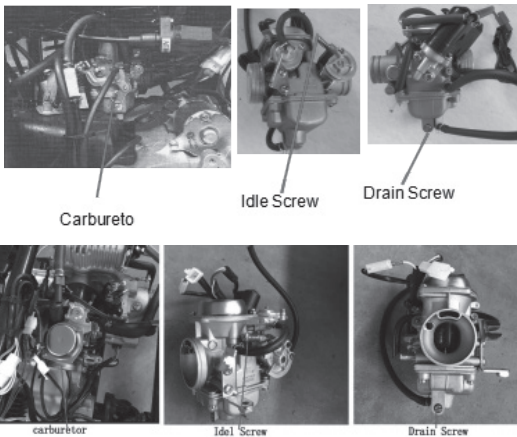

MAINTENANCE

1. Place the transmission in neutral.
2. Set the parking brake.
3. Start the engine and allow it to warm up for approximately five minutes.
4. Turn the carburetor idle screw in (clockwise) to raise RPM. Turn the screw out (counterclockwise) to lower RPM.

Brakes

The front and rear brakes are hydraulic disc type brakes activated by the brake pedal. See page 43.

Always check brake pedal travel and the brake fluid reservoir level before each use of the vehicle. When applied, the brake pedal should feel firm. Any sponginess would indicate a possible fluid leak or low brake fluid level, which must be corrected before riding. See page 78 for brake fluid information.

If you discover any irregularities in brake system operation, including excessive pedal travel, contact your dealer for proper diagnosis and repairs.



Operating the vehicle with a spongy brake pedal can result in loss of braking, which could cause an accident resulting in severe injury or death. Never operate the vehicle with a spongy-feeling brake pedal.

Brake Inspection

1. Check the brake system for fluid leaks.
2. Check the brake pedal for excessive travel or a spongy feel.
3. Check the friction pads for wear, damage and looseness.
4. Inspect the brake pad wear surface for excessive wear.
5. Change pads when worn to 3/64" (1 mm).

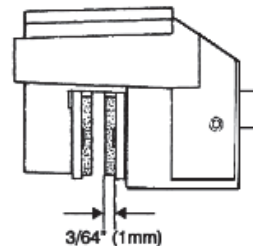

MAINTENANCE

Brakes

Brake Fluid

Inspect the level of the brake fluid before each operation. If the fluid level is low add DOT 4 brake fluid only. See page 118 for the part numbers of Yours products.



After opening a bottle of brake fluid, always discard any unused portion. Never store or use a partial bottle. Brake fluid is hygroscopic, meaning it rapidly absorbs moisture from the air.

The moisture causes the boiling temperature of the brake fluid to drop, which can lead to early brake fade and the possibility of accident or severe injury.

Change the brake fluid every two years any time the fluid becomes contaminated, the fluid level is below the minimum, or if the type and brand of the fluid in the reservoir are unknown.

Access the brake fluid reservoir through the left front wheel well.

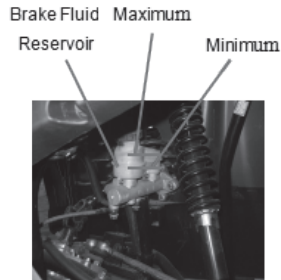

1. Position the vehicle on a level surface.
2. Place the transmission in neutral. Set the parking brake.
3. View the brake fluid level in the reservoir. The level should be between the maximum and minimum level lines. Add brake fluid as needed.
4. Apply the brake forcefully for a few seconds and check for fluid leakage around the fittings.

MAINTENANCE

Steering Wheel Inspection

Check the steering wheel for specified freeplay and smooth operation at the intervals outlined in the Periodic Maintenance Chart beginning on page 64.

1. Position the vehicle on level ground.
2. Lightly turn the steering wheel left and right.
3. There should be 0.8"–1.0" (20–25 mm) of freeplay.
4. If there is excessive freeplay or strange noises, or the steering feels rough or "catchy," have the steering system inspected by an authorized Yours dealer.

Shock Spring Adjustment

The front and rear shock absorber springs are adjustable to increase or decrease spring tension. Rotate the adjuster either clockwise or counter-clockwise to make adjustments. Always apply the same adjustment setting to all four wheels.

WARNING! Uneven adjustment may cause poor handling of the vehicle, which could result in an accident. Always adjust both the left and right spring preloads equally or have your Yours dealer perform the adjustments.

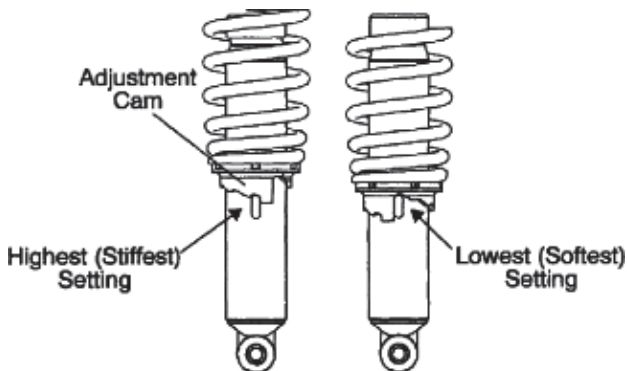

MAINTENANCE

Toe Alignment

Use the following procedure to check the toe alignment of the vehicle.

The recommended toe alignment is 1/8" to 1/4" (3–6 mm) toe out.

WARNING! Severe injury or death can result from improper toe alignment and adjustment. Do not attempt to adjust tie rod alignment. All tie rod adjustments should be performed by an authorized Yours dealer.

1. Position the vehicle on a level surface.
2. Set the handlebars in a straight-ahead position and secure them in this position.



3. Place a chalk mark on the center line of the front tires approximately 10" (25.4 cm) from the floor, or as close to the hub/axle center line as possible.

Make sure both marks are the same distance from the floor.

4. Measure the distance between the marks and record the measurement (1).
5. Move the vehicle to rotate the tires 180°. Position the wheels with the chalk marks at the rear of the tires, even with the hub/axle center line.
6. Measure the distance between the marks and record the measurement (2).
7. Subtract measurement 2 from measurement 1. The difference is the vehicle toe-out alignment.
8. If you discover improper alignment, see your Yours dealer for service.

Tires

! WARNING

Operating your vehicle with worn tires will increase the possibility of skidding, loss of control and an accident, which could result in serious injury or death. Always replace tires when the tread depth measures 1/8" (3 mm) or less.

Improper tire inflation or the use of non-standard size or type of tires may adversely affect vehicle handling, which could result in vehicle damage or personal injury. Always maintain proper tire pressure. When replacing tires, always use original equipment size and type.

Tire Tread Depth

Always replace tires when tread depth is worn to 1/8" (3 mm) or less.

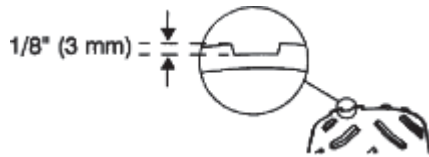

Front Wheel Hub Tightening

Front wheel bearing tightness and spindle nut retention are critical component operations. All service must be performed by your authorized Yours dealer.

Wheel Removal

1. Position the vehicle on a level surface.
2. Place the transmission in neutral. Set the parking brake. Stop the engine.
3. Loosen the wheel nuts slightly.
4. Elevate the side of the vehicle by placing a suitable stand under the frame.
5. Remove the wheel nuts. Remove the wheel.

MAINTENANCE

Tires

Wheel Installation

1. Place the transmission in neutral.
2. Set the parking brake.
3. Place the wheel on the wheel hub with the valve stem toward the outside and the rotation arrows on the tire pointing toward forward rotation.
4. Attach the wheel nuts and finger tighten.
5. Carefully lower the vehicle to the ground.
6. Torque the wheel nuts to specification.

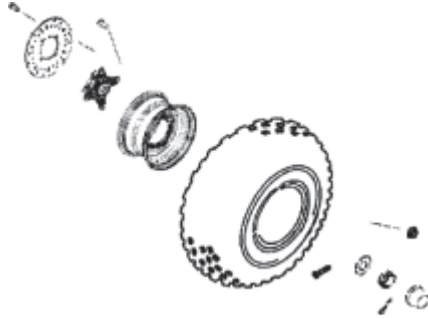

 Improperly installed wheels can adversely affect tire wear and vehicle handling, which can result in serious injury or death. Always ensure that all nuts are torqued to specification. Do not service axle nuts that have a cotter pin installed. See your Yours dealer.

Wheel Nut Torque Specifications

Check the wheel nut torques occasionally and when they've been loosened for service.

Location	Nut Torque
Front Wheel	27 ft. lbs. (37 Nm)
Rear Wheel	27 ft. lbs. (37 Nm)

MAINTENANCE

Lights

Daytime Running Lights Lamp Replacement

If the daytime running lights do not operate, replace the lamps. Yours recommends that you install replacement lamps obtained from your authorized Yours dealer.

1. Disconnect the lights from the harness.
2. Remove the rubber cover from the back of the light assembly.
3. Press the lamp retainer inward and turn it counter-clockwise to remove it. Note the position of the lamp positioning tab, then carefully pull the lamp out.
4. Install the new lamp. Make sure the filament is horizontal.
5. Reinstall the lamp retainer. Press the retainer inward and turn it clockwise about 1/4 turn.
6. Start the engine to make sure the lights come on. If the lights do not operate, see your Yours dealer for service.
7. Reinstall the rubber cover, and reconnect the lights to the harness.

Tail Light Lamp Replacement

If the brake light doesn't work, the lamp may need to be replaced.

1. Remove the two screws securing the lens cover.
Remove the lens cover.
2. Remove the lamp and replace it with a new recommended lamp.
3. Test the light for proper operation.
4. Reinstall the lens cover.

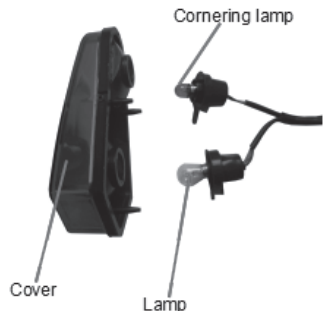

MAINTENANCE

Vehicle Immersion

NOTICE: If your vehicle becomes immersed, major engine damage can result if the machine is not thoroughly inspected. Take the vehicle to your dealer before starting the engine,

If it's impossible to take your vehicle to a dealer before starting it, follow the steps outlined below.

1. Move the vehicle to dry land.
2. Turn the fuel valve off.
3. Check the air box. If water is present, dry the air box and replace the filter with a new filter. Thoroughly dry the air pre-filter. See page 78.
4. Remove the spark plugs.
5. Loosen the carburetor drain screw.
6. Turn the engine over several times.
7. Dry the spark plugs and reinstall them, or install new plugs.
8. Tighten the carburetor drain screw.
9. Turn the fuel valve on.
10. Attempt to start the engine. If necessary, repeat the drying procedure.
11. Take the vehicle to your dealer for service as soon as possible, whether you succeed in starting it or not.
12. If water has been ingested into the transmission follow the procedure on page 79 for drying.



Drain Screw

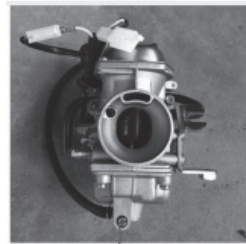

Drain Screw

Battery

! WARNING

Improperly connecting or disconnecting battery cables can result in an explosion and cause serious injury or death. When removing the battery, always disconnect the negative (black) cable first. When reinstalling the battery, always connect the negative (black) cable last.

! WARNING

Battery electrolyte is poisonous. It contains sulfuric acid. Serious burns can result from contact with skin, eyes or clothing.

Antidote:

External: Flush with water.

Internal: Drink large quantities of water or milk. Follow with milk of magnesia, beaten egg, or vegetable oil. Call physician immediately.

Eyes: Flush with water for 15 minutes and get prompt medical attention. Batteries produce explosive gases. Keep sparks, flame, cigarettes, etc. away.

Ventilate when charging or using in an enclosed space. Always shield eyes when working near batteries. **KEEP OUT OF REACH OF CHILDREN.**

Your vehicle may have either a sealed battery, which requires little maintenance, or a conventional battery. A sealed battery can be identified by its flat covers on the top of the battery. A conventional battery has six filler caps on the top of the battery.

Always keep battery terminals and connections free of corrosion. If cleaning is necessary, remove the corrosion with a stiff wire brush. Wash with a solution of one tablespoon baking soda and one cup water, Rinse well with tap water and dry off with clean shop towels. Coat the terminals with dielectric grease or petroleum jelly. Be careful not to allow cleaning solution or tap water into a conventional battery.

MAINTENANCE

Battery

Battery Installation

Using a new battery that has not been fully charged can damage the battery and result in a shorter life. It can also hinder vehicle performance. Follow the battery charging instructions on page 89 before installing the battery.

1. Ensure that the battery is fully charged.
2. Place the battery in the battery holder.
3. On conventional batteries, install the battery vent tube. The vent tube must be free of obstructions and securely installed. Route the tube away from the frame and vehicle body to prevent contact with electrolyte.

Battery gases could accumulate in an improperly installed vent tube and cause an explosion, resulting in serious injury or death. Always ensure that the vent tube is free of obstructions and is securely installed as recommended.



4. Coat the terminals with dielectric grease or petroleum jelly.
5. Connect and tighten the red (positive) cable first.
6. Connect and tighten the black (negative) cable last.
7. Verify that cables are properly routed.
8. Reinstall the driver's seat.

MAINTENANCE

Battery

Battery Storage

Whenever the vehicle is not used for a period of three months or more, remove the battery from the vehicle, ensure that it's fully charged, and store it out of the sun in a cool, dry place. Check battery voltage each month during storage and recharge as needed to maintain a full charge.

See page 96.

Tip: Battery charge can be maintained by using a Yours Battery Tender charger or by charging about once a month to make up for normal self-discharge. Battery Tender can be left connected during the storage period, and will automatically charge the battery if the voltage drops below a pre-determined point. See page 118 for the part numbers of Yours products.

Battery Fluid (Conventional Battery)

A poorly maintained battery will deteriorate rapidly. Check the battery fluid level often. Maintain the fluid level between the upper and lower level marks.

Add only distilled water. Tap water contains minerals that are harmful to a battery.

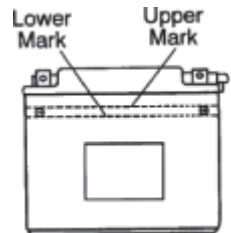

MAINTENANCE

Battery

Battery Charging (Conventional Battery)

1. Remove the battery from the vehicle to prevent damage from leaking or spilled electrolyte during charging. See page 94.
2. Charge the battery with a charging output no larger than 1/10 of the battery's amp/hr rating. Charge as needed to raise the specific gravity to 1.270 or greater.
3. Reinstall the battery. See page 92. Make sure the positive terminal is toward the front of the vehicle.

Battery Charging (Sealed Battery)

The following battery charging instructions apply only to the installation of a sealed battery. Read all instructions before proceeding with the installation of this battery.

The sealed battery is already filled with electrolyte and has been sealed and fully charged at the factory. Never pry the sealing strip off or add any other fluid to this battery.

The single most important thing about maintaining a sealed battery is to keep it fully charged. Since the battery is sealed and the sealing strip cannot be removed, you must use a voltmeter or multimeter to measure DC voltage.

An overheated battery may explode, causing severe injury or death.



Always watch charging times carefully. Stop charging if the battery becomes very warm to the touch. Allow it to cool before resuming charging.

For a refresh charge, follow all instructions carefully.

1. Check the battery voltage with a voltmeter or multimeter. A fully charged battery will register 12.8 V or higher.
2. If the voltage is less than 12.8 volts, recharge the battery at 1.2 amps

MAINTENANCE

or less until battery voltage is 12.8 or greater.

Tip: When using an automatic charger, refer to the charger manufacturer's instructions for recharging. When using a constant current charger, use the guidelines on the next page for recharging.

MAINTENANCE

Battery

Battery Charging (Sealed Battery)

Always verify battery condition before and 1–2 hours after the end of charging.

State of charge	Voltage	Action	Charge Time (Using constant current charger @ standard amps specified on top of battery)
100%	12.8–13.0 volts	None, check at 3 mos. from date of manufacture	None required
5%–100%	12.5–12.8 volts	May need slight charge, if no charge given, check in 3 months	3–6 hours
50%–75%	12.0–12.5 volts	Needs charge	5–11 hours
25%–50%	11.5–12.0 volts	Needs charge	At least 13 hours, verify state of charge
0%–25%	11.5 volts or less	Needs charge with desulfating charger	At least 20 hours

MAINTENANCE

Cleaning and Storage

Washing the Vehicle

Keeping your Yours vehicle clean will not only improve its appearance but it can also extend the life of various components.

Before washing the vehicle, locate the CVT inlet and outlet ducts. The ducts are located under the rear wheel wells. Avoid spraying water directly toward the ducts when washing the vehicle from the rear.

NOTICE: Water in the CVT system could cause the drive belt to become wet and slip in the clutches. Always avoid spraying water directly toward the CVT inlet and outlet ducts when washing the vehicle from the rear.

High water pressure may damage components. Yours recommends washing the vehicle by hand or with a garden hose, using mild soap.

Certain products, including insect repellents and chemicals, will damage plastic surfaces. Do not allow these types of products to contact the vehicle.

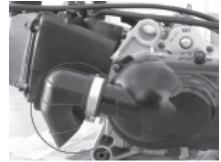

The best and safest way to clean your Yours vehicle is with a garden hose and a pail of mild soap and water.

1. Use a professional-type washing cloth, cleaning the upper body first and the lower parts last.
2. Rinse with clean water frequently.
3. Dry surfaces with a chamois to prevent water spots.

Washing Tips

MAINTENANCE

- Avoid the use of harsh cleaners, which can scratch the finish.
- Do not use a power washer to clean the vehicle.
- Do not use medium to heavy duty compounds on the finish.
- Always use clean cloths and pads for cleaning and polishing. Old or reused cloths and pads may contain dirt particles that will scratch the finish.

MAINTENANCE

Cleaning and Storage

Washing the Vehicle

If a high pressure water system is used for cleaning (not recommended), exercise extreme caution. The water may damage components and could remove paint and labels. Avoid directing the water stream at the following

items:

- Wheel bearings
- Radiator
- Transmission seals
- CVT inlet and outlet ducts
- Brakes
- Cab and body panels
- Labels and decals
- Electrical components and wiring

If an informational or graphic label becomes illegible or comes off, contact your Yours dealer to purchase a replacement. Replacement safety labels are provided by Yours at no charge.

Grease all zerk fittings immediately after washing. Allow the engine to run for a while to evaporate any water that may have entered the engine or exhaust system.

Polishing the Vehicle

Yours recommends the use of common household aerosol furniture polish for polishing the finish on your Yours vehicle. Follow the instructions on the container.

Polishing Tips

- Avoid the use of automotive products, some of which can scratch the finish of your vehicle.
- Always use clean cloths and pads for cleaning and polishing. Old or reused cloths and pads may contain dirt particles that will scratch the finish.

MAINTENANCE

Cleaning and Storage

Chrome Wheel Care (if equipped)

Proper maintenance will protect chrome wheels from corrosion, preserve wheel life and ensure a “like new” appearance for many years.

Tip: Chrome wheels exposed to road salt (or salt in the air in coastal areas) are more susceptible to corrosion if not properly cleaned. Clean chrome wheels more often if they're exposed to salt or other corrosive elements.

1. Wash chrome wheels frequently. Use a mild detergent. Never use abrasive cleaners on plated or painted surfaces.
2. Rinse well with clear water. Soap, detergents, salt, dirt, mud and other elements can cause corrosion.
3. Polish the clean chrome wheels periodically. Use an automotive grade chrome polish.
4. Routinely and liberally apply a weather resistant wax to each polished chrome wheel. Choose a product suitable for chrome finishes. Read and follow the product labels and instructions.

Removing Corrosion

If light rust is found on the chrome finish, use steel wool (#0000–OTT grade) to remove it. Gently rub the affected areas with the steel wool until the corrosion has been removed. Clean and polish the wheel as outlined above.

MAINTENANCE

Cleaning and storage

Storage Tips

NOTICE: Starting the engine during the storage period will disturb the protective film created by fogging and damage could occur. Never start the engine during the storage period.

Clean the Exterior

Make any necessary repairs and clean the vehicle as recommended.

See

page 91.

Stabilize the Fuel

1. Fill the fuel tank.
2. Add Yours Carbon Clean Fuel Treatment or Yours Fuel Stabilizer. Follow the instructions on the container for the recommended amount. Carbon Clean removes water from fuel systems, stabilizes fuel and removes carbon deposits from pistons, rings, valves and exhaust systems.
3. Allow the engine to run for 15–20 minutes to allow the stabilizer to disperse through the fuel in the tank and carburetor.
4. Turn the fuel valve off.
5. Drain the carburetor bowl.

Air Filter / Air Box

Inspect and clean or replace the pre-filter and air filter. See page 78.

Clean the air box. Drain the sediment tube.

Fluid Levels

Inspect the fluid levels. Add or change fluids as recommended in the Periodic Maintenance Chart beginning on page 64.

- Transmission fluid
- Brake fluid (change every two years and any time the fluid looks dark or contaminated)

Engine oil

Change the oil. See page 65.

MAINTENANCE

Cleaning and Storage

Storage Tips

Inspect and Lubricate

Inspect all cables and lubricate all areas of the vehicle as recommended in the Periodic Maintenance Chart beginning on page 64.

Fog the Engine

Use Yours Engine Fogging Oil. Follow label directions carefully.

Battery Maintenance

See pages 97–102 for storage and charging procedures.

Storage Area/Covers

Be sure the storage area is well ventilated. Cover the vehicle with a genuine Yours cover. Do not use plastic or coated materials. They do not allow enough ventilation to prevent condensation, and may promote corrosion and oxidation.

Removal from Storage

1. Check the battery electrolyte level and charge the battery if necessary. Install it in the vehicle. Make sure the battery vent hose is routed properly and that it's not pinched or restricted in any way.
2. Make sure the spark plug is tight.
3. Fill the fuel tank with fuel.
4. Check all the points listed in the Daily Pre–Ride Inspection section on page 47. Tightness of the bolts, nuts and other fasteners should be checked by an authorized Yours dealer.
5. Lubricate at the intervals outlined in the Periodic Maintenance Chart beginning on page 64.

MAINTENANCE

Transporting the Vehicle

Follow these procedures when transporting the vehicle.

1. Place the transmission in neutral. Set the parking brake.
2. Stop the engine.
3. Turn the fuel valve off.
4. Remove the key to prevent loss during transporting.
5. Secure the fuel cap and seats.



NOTICE: Always tie the frame of the Yours vehicle to the transporting unit securely with suitable straps or rope. Do not attach tie straps to the front control arm bolt pockets.

6. Wrap the front tie strap through the frame tubes, or attach a tie-down hook around each of the tubes.
7. Wrap the rear tie strap around the swing arm.

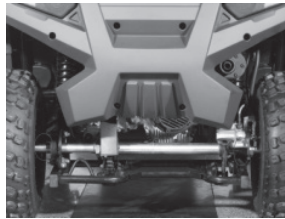

SPECIFICATIONS

UTV 170 /150	
Maximum Rider Weight	150 lbs. (68 kg) (each rider)
Maximum Weight Capacity	300 lbs. (136 kg)
Gross Vehicle Weight	840 lbs. (381 kg)
Dry Weight	540 lbs. (245 kg)
Fuel Capacity	2.5 gal. (9.5 ltr)
Engine Oil Capacity	33 oz. (1.0 ltr)
Transmission Oil Capacity	20.3 oz. (600 ml)
Overall Length	88 in. (225 cm)
Overall Width	48 in. (122 cm)
Overall Height	55 in. (139.7 cm)
Wheelbase	65 in. (165 cm)
Ground Clearance	6 in. (15.2 cm)
Engine Type	4-Stroke
Displacement	169 cc/149.6cc
Cooling	Oil Cooled
Bore x Stroke	61 mm x 57.8 mm//57.4 mm x 57.8 mm
Alternator Output	110 watts
Compression Ratio	9.5:1
Carburetor	1 / 22 mm (VM Type)
Pilot Jet	35
Main Jet	100
Air Screw	2 Turns Out
Jet Needle	2MKNN-4 clip
Starting System	Electric
Ignition System	CDI
Spark Plug / Gap	NGK CR6HSA / 0.6-0.7 mm
Front Suspension	Single A-arm w/5 in. (12.7 cm) travel
Rear Suspension	Dual Shock swing arm w/5 in. (12.7 cm) travel

SPECIFICATIONS

UTV 170 /150	
Lubrication System	Wet Sump
Driving System Type	Automatic Constant Variable Transmission
Final Drive	Chain
Shift Type	F/N/R
Tire Size – Front	19x7–8
Tire Size – Rear	20x10–9
Tire Pressure – Front	14 psi (97kPa)
Tire Pressure – Rear	21 psi (145kPa)
Brakes, Front/Rear	Foot Activated, 4–wheel hydraulic disc
Parking Brake	Mechanical, Rear (Lever)
Daytime Running Lights	Dual, Standard
Brake Light	Standard

SPECIFICATIONS

UTV 250	
Engine type	4-stroke, Single-Cylinder, Air/Oil-cooled
Engine style	Australia Design
Displacement	232cc
Horse Power	10.5kw(7500r/min) 14.5HP
Valve Configuration	OHV
Compression ratio	10.3:1
Fuel Delivery System	Fuel Pump+Vacuum Diaphragm Carburetor
Choke System	Automatic
Fuel capacity	9.5L (2.1 Gallon)
Fuel meter	LED Fuel Meter
Driveline Type	2X4
Final Drive	Shaft-Drive
Transmission	Constantly Variable Transmission
Gear Selection	R-N-D
Speed meter	LED Speed Meter
Forward Lights	High & Low Beam
Heading Light	LED
Driving Light	LED
Rear Lights	Brake Lights & Left/Right Signal lights
Starting system	Electric start
Ignition system	D.C.D.I
Suspension Front	Double A-arm Suspension
Suspension Rear	Fang power 4-Link® bar Rear Suspension
Brakes Front	Front Dual Hydraulic Disk
Brakes Rear	Rear Dual Hydraulic Disk
Front Tread	1150mm (45.3 in)
Rear Tread	1040mm (41in)
Front & Rear tire size	25x8-12 / 25x10-12

SPECIFICATIONS

Front & Rear rim size(Alloy)	12x6 / 12x8
Manufacturers Defect Warranty	6 Months
Top speed	60km/h
Dry weight	280kg (750lbs.)
Gross weight	348kgs(766lbs)
Wheelbase	1980mm (78in)
Vehicle dimension (L x W x H)	2590x1350x1660mm (102x 53x65.4 in)
(Heading Light Height included)	260mm (10.2in)
Ground clearance	Driver & Passenger Triple Point Fix Seat
Safety	Belts/ Metal Semi-Door

SPECIFICATIONS

400CC UTV	
Engine Type	4 Stroke,with balance shaft,Water Cooled
Max.Power(kw/rpm)	15.2KW @ 7000rpm
Max.Torque(NM/rpm)	28N.M @ 5500rpm
Cylinder No.	Single Cylinder
Bore Stroke	78mm × 75.2mm
Displacement	359.1ml
Compression Ration	10.5:1
Spark Plug	DR8EA
Starting	Electric Start & Hang Pull
Ignition	C.D.I
Fuel Delivery System	Fuel Pump+Vacuum Diaphragm Carburetor
Choke System	Automatic
Fuel capacity	9.5L (2.1 Gallon)
Fuel meter	LED Fuel Meter
Driveline Type	2X4
Final Drive	Shaft-Drive
Transmission	Constantly Variable Transmission
Gear Selection	R-N-D
Speed meter	LED Speed Meter
Forward Lights	High & Low Beam
Heading Light	LED
Driving Light	LED
Rear Lights	Brake Lights & Left/Right Signal lights
Starting system	Electric start
Ignition system	D.C.D.I
Suspension Front	Double A-arm Suspension
Suspension Rear	Fang power 4-Link® bar Rear Suspension
Brakes Front	Front Dual Hydraulic Disk

SPECIFICATIONS

Brakes Rear	Rear Dual Hydraulic Disk
Front Tread	1150mm (45.3 in)
Rear Tread	1040mm (41in)
Front & Rear tire size	25x8-12 / 25x10-12
Front & Rear rim size(Alloy)	12x6 / 12x8
Manufacturers Defect Warranty	6 Months
Top speed	60km/h
Dry weight	280kg (750lbs.)
Gross weight	348kgs(766lbs)
Wheelbase	1980mm (78in)
Vehicle dimension (L × W × H) (Heading Light Height included)	2590x1350x1660mm (102x 53x65.4 in)
Ground clearance	260mm (10.2in)

Jetting and Clutching

Please see your Yours dealer for jetting and clutching specifications. To access clutches for inspection, remove the passenger seat and remove the clutch access panel. See page 36.

SPECIFICATIONS

BMS Sniper 350 T1	
Engine Type	4 Stroke,with balance shaft,Water Cooled
Max.Power(kw/rpm)	14KW @ 6800rpm
Max.Torque(NM/rpm)	25N.M @ 5000rpm
Cylinder No.	Single Cylinder
Bore Stroke	78mm × 65.2mm
Displacement	311.4ml
Compression Ration	10.5:1
Spark Plug	DR8EA
Starting	Electric Start & Hang Pull
Ignition	C.D.I
Fuel Delivery System	Fuel Pump+Vacuum Diaphragm Carburetor
Choke System	Automatic
Fuel capacity	9.5L (2.1 Gallon)
Fuel meter	LED Fuel Meter
Driveline Type	2X4
Final Drive	Shaft-Drive
Transmission	Constantly Variable Transmission
Gear Selection	R-N-D
Speed meter	LED Speed Meter
Forward Lights	High & Low Beam
Heading Light	LED
Driving Light	LED
Rear Lights	Brake Lights & Left/Right Signal lights
Starting system	Electric start
Ignition system	D.C.D.I
Suspension Front	Double A-arm Suspension
Suspension Rear	Fang power 4-Link bar Rear Suspension
Brakes Front	Front Dual Hydraulic Disk

SPECIFICATIONS

Brakes Rear	Rear Dual Hydraulic Disk
Front Tread	1150mm (45.3 in)
Rear Tread	1040mm (41in)
Front & Rear tire size	25x8-12 / 25x10-12
Front & Rear rim size(Alloy)	12x6 / 12x8
Manufacturers Defect Warranty	6 Months
Top speed	60km/h
Dry weight	280kg (750lbs.)
Gross weight	348kgs(766lbs)
Wheelbase	1980mm (78in)
Vehicle dimension (L x W x H) (Heading Light Height included)	2590x1350x1660mm (102x 53x65.4 in)
Ground clearance	260mm (10.2in)

Jetting and Clutching

Please see your Yours dealer for jetting and clutching specifications. To access clutches for inspection, remove the passenger seat and remove the clutch access panel. See page 36.

TROUBLESHOOTING

Drive Belt Wear/Burn

Part cause	Solution
Driving at low RPM or ground speed	Drive at a higher speed.
Insufficient warm-up at low ambient temperatures	Warm the engine at least 5 minutes. With the transmission in neutral, apply small amount of throttle in short bursts, 5 to 7 times. The belt will become
	more flexible and prevent belt burning.
Slow/easy clutch engagement Belt slippage from water or snow ingestion into the CVT system	Use the throttle quickly and effectively. Dry out the CVT (see page 71). Prevent water from entering the CVT inlet and outlet ducts (see page 91). Inspect clutch seals for damage if
	repeated leaking occurs.
Clutch malfunction	See your Yours dealer.
Poor engine performance	Check for fouled plugs or foreign material in gas tank or fuel lines. See
	your dealer.
Wrong or missing belt	Install the recommended belt.
Improper break-in	Always break in a new belt and/or clutch. See page 41.

TROUBLESHOOTING

Engine Doesn't Turn Over

Possible Cause	Solution
Low battery voltage	Recharge the battery to 12.8 VDC
Loose battery connections	Check all connections and tighten
Loose solenoid connections	Check all connections and tighten

Engine Turns Over, Fails to Start

Possible Cause	Solution
Out of fuel	Turn the fuel valve to reserve, refuel
Clogged fuel valve or filter	Inspect and clean or replace
Water is present in fuel	Drain the fuel system and refuel
Old or non-recommended fuel	Replace with fresh recommended fuel
Fuel valve is turned off	Turn the fuel valve on
Fouled or defective spark plugs	Inspect plugs and replace if necessary
No spark to spark plug	Inspect plugs and replace if necessary
Water or fuel in crankcase	Immediately see your Yours dealer
Overuse of choke	Inspect, clean and/or replace spark plugs
Clogged fuel filter	Replace the filter
Low battery voltage	Recharge the battery to 12.8 VDC
Mechanical failure	See your dealer

Engine Backfires

Possible Cause	Solution
Weak spark from spark plug	Inspect, clean and/or replace spark plugs
Incorrect spark plug gap or heat range	Set gap to specs or replace plugs
Old or non-recommended fuel	Replace with fresh recommended fuel
Incorrectly installed spark plug wires	See your dealer
Incorrect ignition timing	See your dealer
Mechanical failure	See your dealer
Loose ignition connections	Check all connections and tighten
Water present in fuel	Replace with fresh recommended fuel
Exhaust system leak	See your dealer

TROUBLESHOOTING

Engine Pings or Knocks

Possible Cause	Solution
Poor quality or low octane fuel	Replace with recommended fuel
Incorrect ignition timing	See your dealer
Incorrect spark plug gap or heat range	Set gap to specs or replace plugs

Engine Runs Irregularly, Stalls or Misfires

Possible Cause	Solution
Fouled or defective spark plugs	Inspect, clean and/or replace spark plugs
Worn or defective spark plug wires	See your dealer
Incorrect spark plug gap or heat range	Set gap to specs or replace plugs
Loose ignition connections	Check all connections and tighten
Water present in fuel	Replace with new fuel
Low battery voltage	Recharge battery to 12.8 VDC
Kinked or plugged fuel tank vent line	Inspect and replace
Incorrect fuel	Replace with recommended fuel
Clogged air filter	Inspect and clean or replace
Electronic throttle control malfunction	See your dealer
Other mechanical failure	See your dealer
Possible Lean Fuel Cause	Solution
Low or contaminated fuel	Add or change fuel, clean the fuel system
Low octane fuel	Replace with recommended fuel
Clogged fuel filter	See your dealer
Incorrect fuel	Replace with recommended fuel
Incorrect jetting	See your dealer
Possible Rich Fuel Cause	Solution
Fuel is very high octane	Replace with lower octane fuel
Overuse of choke	Inspect, clean and/or replace spark plugs
Stopping/starting without adequate Warm-up	Allow engine to warm up before operating and/or stopping
Incorrect fuel	Replace with recommended fuel
Clogged air filter	Inspect and clean or replace
Incorrect jetting	See your dealer

TROUBLESHOOTING

Engine Stops or Loses Power

Possible Cause	Solution
Out of fuel	Refuel
Kinked or plugged fuel vent line	Inspect and replace
Overuse of choke	Inspect, clean and/or replace spark plugs
Water is present in fuel	Replace with new fuel
Fouled or defective spark plugs	Inspect, clean and/or replace spark plug
Worn or defective spark plug wires	See your dealer
Incorrect spark plug gap or heat range	Set gap to specs or replace plug
Loose ignition connections	Check all connections and tighten
Low battery voltage	Recharge the battery to 12.8 VDC
Incorrect fuel	Replace with fresh recommended fuel
Clogged air filter	Inspect and clean or replace
Electronic throttle control malfunction	See your dealer
Other mechanical failure	See your dealer

MAINTENANCE LOG

Use the following chart to record periodic maintenance.

DATE	MILES (KM) OR HOURS	TECHNICIAN	SERVICE PERFORMED / COMMENTS

MAINTENANCE LOG

Use the following chart to record periodic maintenance.

DATE	MILES (KM) OR HOURS	TECHNICIAN	SERVICE PERFORMED / COMMENTS

INDEX

A

Air Filter.....	78
Arrestor, Spark, Warning.....	79

B

Battery	91-102
Charging (Conventional).....	94
Charging (Sealed).....	96
Fluid Replenishment.....	93
Installation.....	92
Removal.....	102
Storage.....	93
Before Riding.....	46
Belt Burning.....	112
Belt Wear.....	112
Belts, Seat.....	37-38
Boots.....	14
Brake Fluid.....	84
Brake Inspection.....	83
Brake Pedal.....	43
Brake System Break-in.....	46
Brakes.....	84
Braking.....	50
Break-In Period.....	45-46
Burning Belts.....	112

C

Cab Nets.....	39
Cap, Fuel.....	40
Carburetor.....	82
Carburetor Adjustment.....	82
Changing Gears.....	42
Chart, Periodic Maintenance.....	64-66
Chrome Wheel Care.....	100
Cleaning and Storage.....	97-102
Cleaning the Air Filter.....	78
Cleaning, Exhaust System.....	79
Cleaning, Spark Arrestor.....	79
Clothing.....	14
Clutching.....	109
Component Locations.....	32-34
Condition, Spark Plugs.....	74

C

Constant Variable Transmission.....	76
Corrosion Removal, Chrome.....	100
Cover for Storage.....	102
Crankcase Emission Control System.....	61
CVT Break-In.....	46
CVT Drying.....	76
CVT System.....	76

D

Drive Belt Wear.....	112
Drive Chain Lubrication.....	72
Drive Chain Slack.....	72
Drive Chain Slack Adjustment.....	73
Drivetrain Break-In.....	46
Driving Downhill.....	56
Driving in Reverse.....	59
Driving on a Sidehill.....	56
Driving on Slippery Surfaces.....	54
Driving Over Obstacles.....	58
Driving Procedures.....	51-52
Driving Through Water.....	57
Driving Uphill.....	55
Driving with a Passenger.....	53

E

Electromagnetic Interference.....	61
Emission Control, Crankcase.....	61
Emission Control, Exhaust.....	61
Emission Control, Noise.....	61
Engine Break-In.....	46
Engine Fogging.....	102
Engine Idle RPM Adjustment.....	83
Engine Oil.....	68-69
Engine Stopping.....	50
Equipment Modifications.....	12
Exhaust Cleaning.....	79
Exhaust Emission Control System.....	61
Exhaust System Warning.....	79
Eye Protection.....	14

INDEX

F	J
Filling the Battery.....93	Jetting.....109
Filter Care During Storage.....101	K
Filter Cleaning, Air.....77	Key, Periodic Maintenance Chart.....64
Filter Systems.....77	L
Filter, Air.....77	Lamp Replacement
Fluid, Main Gearcase.....70	Tail Light.....89
Fluid, Transmission.....70	Daytime Running Lights.....89
Fluid Levels During Storage.....101	Lights.....89
Fluid, Battery.....93	Lubricant Part Numbers.....102
Fluid, Brake.....84	Lubrication for Storage.....102
Fogging the Engine.....102	Lubrication Recommendations.....67
Fouled Plugs.....74	M
Freeplay Adjustment, Throttle.....80	Maintenance Log.....116-117
Freeplay, Steering Wheel.....85	Maintenance, Periodic.....64-66
Fuel Cap.....40	N
Fuel Safety.....28	Nets, Cab.....39
Fuel Stabilizer.....101	New Operator Procedures.....51-52
Fuel Tank Filler Cap.....40	Noise Emission Control System.....61
Fuel Valve.....40	O
G	Obstacles.....58
Gap, Spark Plug.....74	Oil
Gasoline Handling.....28	Engine.....69
Gear Selector.....42	Main Gearcase.....70
Gearcase Oil.....70	Transmission.....70
Gearcase, Main.....70	Oil Change
Gears, Shifting.....42	Engine.....69
Gloves.....14	Main Gearcase.....70
H	Transmission.....70
Hand Hold, Passenger.....36	Oil Check
Helmet.....13	Engine.....68
I	Main Gearcase.....70
Idle RPM Adjustment.....82	Transmission.....70
Ignition Switch.....41	Operation on Public Lands.....61
Inspection, Brakes.....84	
Inspection, Pre-Ride.....47	
Inspection, Seat Belts.....38	
Inspection, Steering Wheel.....85	
Inspection, Throttle Freeplay.....80	
Installation, Battery.....92	
Installation, Wheels.....87	
Interference, Electromagnetic.....61	

INDEX

Parking on an Incline.....	60
Parking the Vehicle.....	50
Passenger Hand Hold Adjustment.	36
Periodic Maintenance Chart.....	64–66
Plug Condition.....	74
Plug Gap.....	74
Plug Torque.....	74
Plugs, Fouled.....	75
Plugs, Spark.....	74–75
Yours Products.....	102
Polishing the Vehicle.....	99
Pre-Ride Inspection.....	46
Public Lands.....	61

R

Removal, Battery.....	92
Removal, Seat.....	35
Removal, Wheels.....	86
Removing the Vehicle from Storage..	102
Reverse.....	59
Riding Gear.....	13–14

S

Safe Operation Practices.....	48
Safety Labels.....	30–31
Safety Symbols.....	12
Safety Warnings.....	15–31
Accessories.....	17
Age Restrictions.....	16
Cab Nets/Side Guards.....	18
Carrying a Passenger.....	19
Crossing Hillside.....	24
Driving Downhill Improperly.....	23
Excessive Speeds.....	21
Exposure to Exhaust.....	28
Failure to Inspect.....	17
Frozen Bodies of Water.....	27
Handling Gasoline.....	28
Hot Exhaust Systems.....	28
Improper Hill Climbing.....	23
Improper Tires & Maintenance..	25
Instruction.....	15
Jumps and Stunts.....	22

Safety Warnings.....	15–31
Multiple Passengers.....	19
Obstacles.....	26
Operating a Damaged Vehicle.....	27
Operating on Sand.....	25
Operating Through Water.....	26
Overloading.....	27
Pavement.....	19
Physical Control.....	20
Protective Apparel.....	17
Public Roads.....	19
Reverse.....	25
Rider Height.....	17
Seat Belts.....	18
Skidding or Sliding.....	26
Slippery Terrain.....	25
Stalling on a Hill.....	24
Turning Improperly.....	21
Unauthorized Use of Vehicle.....	29
Unfamiliar Terrain.....	24
Using Alcohol or Drugs.....	19
Seat Adjustment, Driver's.....	35
Seat Belt Cleaning.....	38
Seat Belt Inspection.....	38
Seat Belts.....	37–38
Seat Removal.....	35
Selector, Gear.....	42
Severe Use Definition.....	62
Shifting Gears.....	42
Shock Spring Adjustment.....	85
Side Guards.....	39
Signal Words.....	9
Spark Arrestor Cleaning.....	79
Spark Arrestor Warning.....	79
Spark Plug Condition.....	9
Spark Plug Gap.....	74
Spark Plug Removal.....	75
Spark Plug.....	Plug
Torque.....	74
Spark Plugs.....	74–75
Spark Plugs, Fouled.....	75
Specifications.....	104–111
Speed Control System.....	44
Stabilizing the Fuel.....	101
Steering Wheel Adjustment.....	36
Steering Wheel Inspection.....	85

INDEX

Storage.....	93-102
Storage and Inspection.....	102
Storage..... and	
Lubrication.....	95
Storage Area.....	102
Storage, Battery.....	93
Storage, Covers.....	102
Storage, Fluid Levels.....	101
Storage, Oil Change.....	101
Storage, Removal.....	102

T

Tail Light.....	89
Throttle Freeplay Adjustment.....	80
Throttle Freeplay Inspection	80
Throttle Freeplay, Freeplay, Throttle.	80
Throttle Pedal.....	43
Throttle System.....	80
Tire Tread Depth.....	87
Tires.....	87-88
Front Wheel Hub Tightening.....	87
Wheel Nut Torque.....	88
Toe Alignment.....	86
Torque, Spark Plug.....	74
Transmission Oil.....	70
Transmission.....	70
Transporting the Vehicle.....	103
Tread Depth, Tire.....	87

Vehicle Identification Numbers.....	11
Vehicle Immersion.....	90
Vehicle Transport.....	103

W

Warning Symbols.....	9
Washing the Vehicle.....	93-94
Water, Immersion of Vehicle.....	90
Wear, Drive Belt.....	112
Wheel Hub Tightening.....	87
Wheel Installation.....	88
Wheel Nut Torque Specifications.....	88
Wheel Removal.....	87

WARNING

Improper vehicle use can result in SEVERE INJURY or DEATH

NEVER allow vehicle to be operated:

- without all occupants first viewing and understanding safety video and warning labels.
- with more than one passenger.
- on hills steeper than 15 degrees $\angle 15^\circ$.
- on paved surfaces - pavement may seriously affect handling and control.
- with non-Yours approved accessories - they may seriously affect stability.
- at speeds that are too fast for the operator's skills, the conditions and/or the terrain.

ALWAYS require operator and passenger to:

- wear seat belts, grab hand holds (passenger) and plant feet firmly on the floor.
- secure cab nets.
- keep hands and feet inside vehicle.
- avoid quick turns of the steering wheel and driving stunts such as jumps, donuts or power slides.
- reduce speed and use extra caution when carrying a passenger.
- watch for branches or other hazards that could enter vehicle.

Operation of this vehicle by children age 16 and under increases the risk of severe injury or death. Adult supervision required for children under age 16. NEVER permit children age 16 and under to operate or ride in this vehicle.

LOCATE AND READ OWNER'S MANUAL. FOLLOW ALL INSTRUCTIONS AND WARNINGS. IF OWNER'S MANUAL IS MISSING, CONTACT A YOURS DEALER FOR A REPLACEMENT.